



Catalog

Best On The Floor!

shepherd
HARDWARE PRODUCTS

Shepherd Hardware Products
has produced enough FeltGard®
pads, that if placed side by side,
would stretch all the way from
New York to Los Angeles.

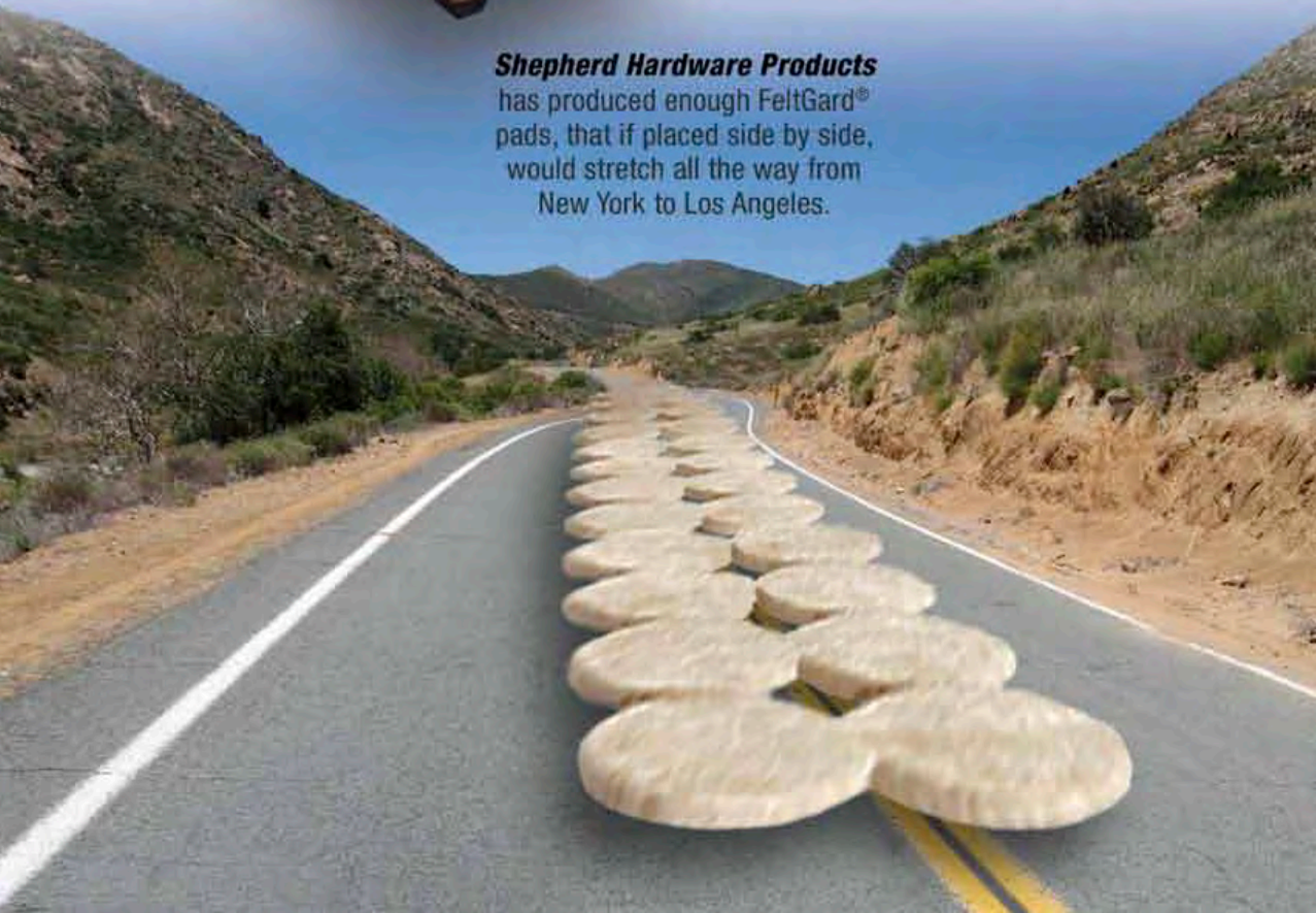

TERMS & CONDITIONS



Terms of Payment

Net thirty (30) days from date of invoice with approved credit.
MasterCard, Visa, or cash-in-advance for miscellaneous accounts.

Minimum Prepaid Freight Order

\$500 minimum order for prepaid freight (standard ground) within the continental US for established accounts. Miscellaneous accounts are freight collect. Orders will be adjusted to conform to standard packaging quantities.

Product Specification

We reserve the right to adjust product specification in line with our policy of continuous development.

Return Merchandise

Written authorization must be obtained from Shepherd Hardware Products LLC before merchandise may be returned. All merchandise must be shipped on a pre-paid basis and is subject to a 20% handling charge.

Claims

Claims for shortage of goods must be made within three (3) working days from receipt of goods.

Pricing

Prices may be subject to change without prior notice.

Order Acknowledgement

Confirmation/acknowledgement of order receipt is not sent as standard procedure.

Title

Goods supplied remain the property of Shepherd Hardware Products LLC until payment is received in full.

Overdue Accounts

We reserve the right to charge a late fee of 1.5% per month on the unpaid total balance due when more than thirty (30) days past due.

TABLE OF CONTENTS

Appliance Movers	
Appliance Casters	5
Appliance Rollers	5
Casters	
Furniture Casters	
Ball Casters	
Hooded Ball Casters	3
Soft Tread Metal Ball Casters	3
Bed Rollers	
Adjustable Bed Casters	5
Wide Wheel Bed Casters	5
Twin Wheel Casters	
Twin Wheel Casters	4
Miscellaneous	
Economical Light Duty Casters	6
Friction Grip Ring Casters	7
G1 Series Casters	7
Medium Duty Casters	6-7
Threaded Stem Casters	7
Wood Casters	6
Industrial Casters	
Cast Iron Wheel	12
Hard Rubber Wheel	11
Mold-On Rubber Wheel	11
Phenolic Wheel	14
Pneumatic Wheel	15
Polyamide Wheel	14
Polypropylene Wheel	13
Mold-On Polyurethane Wheel	12
Soft Rubber Wheel	8-10
Caster Cups	
Carpet Base Metal Cups	30
Plastic Cups	30
Smooth Rubber Cups	30
Wood Grain Cups - Felt/TPR	30
Casual Furniture Line	
Inserts	35
Patio Cups	35
Patio Stem Bumpers	35
Plastic Patio Tips	35
Umbrella Hole Ring Set	35
Dollies & Trucks	
Movers Dolly	18
Plant Dolly	18
Platform Trucks	18
Snowmobile Dolly	18
Tri-Dollies	18
Door Products	
Door Stops	31
Rubber Wedges	31
Floor Savers	
FeltGard® Merchandisers	40-43
FeltGard Plus®	20-21
Heavy Duty Felt Pads	22-23
Glides	
Furniture Glides	
Anti-Skid	23
Nail-on Glides	26
Swivel Glides	26
Tack Glides	26
Threaded Stem Glides	26
Low Friction Glides	
Slide Glide®	24
Slide Glide® Plus	25
Slider n Gripper Glides	
Cups, Glides & Pads	27
Hooks	
Heavy Duty Vinyl Coated Hooks	37
Lazy Susan	
Lazy Susan Turntables	36
Leg Tips	
Angle Tips	34
Crutch Tips	32
Inside Tips	34
Plastic Tips	32
Plastic Tips with Felt	34
Rubber Tips	33
Square Tips	34
Vinyl Tips	32
Replacement Wheels	
Flat-Free Wheel	17
Full Pneumatic Wheelbarrow Wheel	17
Hand Truck Replacement Wheels	17
Metal Hub Semi-Pneumatic Rubber Tires	16
Plastic Hub Semi-Pneumatic Rubber Tires	16
Pneumatic Wheel - Roller Bearings	17
Wheel Tree Merchandiser Displays	39
Wheelbarrow Wheel	17
Sockets	
Metal Sockets	5
Plastic Sockets	5
Surface Grip	
Anti-Skid Pads	23
Surface Savers	
Bumpers	29
Cork Self-Adhesive Pads	29
Foam Non-Skid Self-Adhesive Pads	29
Light Duty Self-Adhesive Felt Pads	28
Medium Duty Self-Adhesive Felt Pads	28
Vinyl Self-Adhesive Pads	29
Table Levelers	
WonderLevel	27
Variety Packs	
Assortments of Popular Shepherd Products	42-43
Wedge It®	
Plastic Shims	36

HOW TO SELECT THE RIGHT SHEPHERD CASTER

1 Consider the Load Rating

First, figure out the load rating per caster you will require to safely move the desired object. Keep in mind, the larger the total load is, the larger the wheel will be. You can carry heavier loads with smaller wheels, if you utilize several casters.

EX. Load + Weight of cart-truck / number of casters = lbs per caster







2 Consider the Caster Type

- **Swivel Casters:** Swivel 360 degrees, which allows for easy movement of the load in any direction.
- **Rigid Casters:** Do not swivel. They are mounted in a way that allows them to go forwards and backwards only.
- **Swivel Casters with Brake:** Same as swivel but also feature a brake that when activated, will not allow the wheel to roll.

3 Consider the Wheel Type

- Make sure the wheel selected is large enough to pass over cracks in the floor and other obstructions.
- If the casters are to be used on very rough surface, a larger wheel size is recommended.
- Rubber wheels offer good floor protection, noise reduction and have a cushion effect on load.

CASTER FASTENERS					
	02 Stem 5/16" x 1-1/2"		05 Stem 3/8" x 1-1/2"		82 Stem 7/16" x 1-7/16"
	04 Stem 3/8" x 1-1/2"		07 Stem 5/16" x 1"		87 Stem 3/8" x 1"
			45 Stem 5/16" x 7/8"		88 Stem 7/16" x 7/8"
					Round Plate 1 1/16"
					01 Plate 1-1/2" SQ. 13 Plate 1-1/8" x 2" 18 Plate 1-1/2" x 2-1/8"
STEMS			PLATES		

HOODED BALL CASTERS

Black soft tread wheel for use on small sofas, upholstered chairs, TV stands, microwave carts, servers, etc. Double race ball bearing construction.

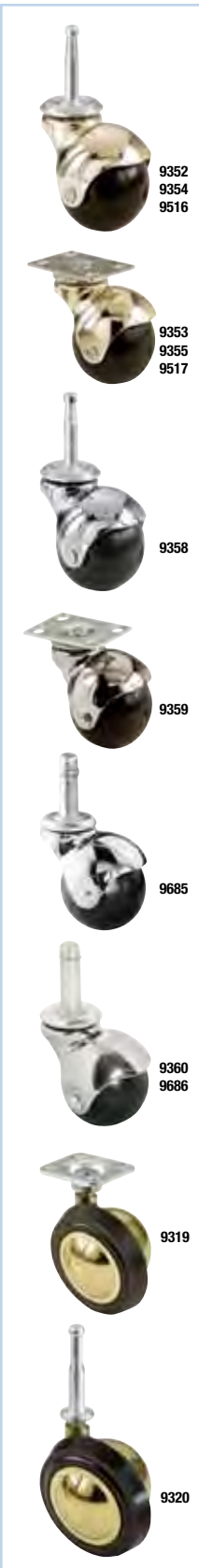

»» Hooded Ball Casters

ITEM #	DESCRIPTION	LOAD CAP LB (KG)	U.P.C. (0 39003)	PCS/ PKG	PKG/ CTN
★ 9352	1-5/8" (40mm) Bright Brass - Stem 02	75lb (34kg)	09352 8	2	6
★ 9353	1-5/8" (40mm) Bright Brass - Plate 13	75lb (34kg)	09353 5	2	6
9354	2" (50mm) Bright Brass - Stem 02	80lb (36kg)	09354 2	2	6
★ 9355	2" (50mm) Bright Brass - Plate 18	80lb (36kg)	09355 9	2	6
▶ 9358	2" (50mm) Bright Chrome - Stem 02	80lb (36kg)	09358 0	2	6
▶ 9359	2" (50mm) Bright Chrome - Plate 18	80lb (36kg)	09359 7	2	6
▶ 9360	2" (50mm) Bright Chrome - Stem 82	80lb (36kg)	09360 3	2	6
★ 9685	2" (50mm) Bright Chrome - Stem 87	80lb (36kg)	09685 7	1	6
★ 9686	2" (50mm) Bright Chrome - Stem 82	80lb (36kg)	09686 4	1	6

- ★ Not Stocked in Canada – Call for Lead-time
- ▶ Available Only in Canada

»» Hooded Ball Casters - Bulk

ITEM #	DESCRIPTION	LOAD CAP LB (KG)	U.P.C. (0 39003)	PCS/ CTN
★ 9516	2" (50mm) Bright Brass - Stem 02	80lb (36kg)	09516 4	12
★ 9517	2" (50mm) Bright Brass - Plate 18	80lb (36kg)	09517 1	12

- ★ Not Stocked in Canada – Call for Lead-time

METAL BALL CASTERS

Shepherd Soft Tread Metal Ball casters offer outstanding mobility. Tough, long lasting die-cast metal alloy will stand up to hard use and rubber treads offer quiet movement. Self-lubricating. For use on sofas, upholstered chairs, TV stands, servers, etc.

»» Soft Tread Metal Ball Casters - Bulk

ITEM #	DESCRIPTION	LOAD CAP LB (KG)	U.P.C. (0 39003)	PCS/ PKG	PKG/ CTN
▶ 9319	2-1/4" (57mm) Bright Brass - Plate 01	75lb (34kg)	09319 1	2	6
▶ 9320	2-1/4" (57mm) Bright Brass - Stem 02	75lb (34kg)	09320 7	2	6

- ▶ Available only in Canada

TWIN WHEELS

Twin wheels place more wheel surface on the carpet pile, and move in opposite directions to minimize carpet fiber twisting. For use on RTA furniture, office chairs, printer stands, entertainment centers, and other items.

»» Twin Wheels Casters

ITEM #	DESCRIPTION	LOAD CAP LB (KG)	U.P.C. (0 39003)	PCS/ PKG	PKG. CTN
9401	1-5/8" (40mm) Black - Plate 01	40lb (18kg)	09401 3	2	6
9402	1-5/8" (40mm) Black - Stem 02	40lb (18kg)	09402 0	2	6
9420	1-5/8" (40mm) U-Bracket	40lb (18kg)	09420 4	2	6
9403	2" (50mm) Black Soft Tread - Plate 01	<i>HSF</i> 75lb (34kg)	09403 7	2	6
9404	2" (50mm) Black Soft Tread - Stem 02	<i>HSF</i> 75lb (34kg)	09404 4	2	6
9405	2" (50mm) Black w/Brake - Plate 01	75lb (34kg)	09405 1	2	6
9406	2" (50mm) Black w/Brake - Stem 02	75lb (34kg)	09406 8	2	6
9417	2" (50mm) Black - Plate 01	75lb (34kg)	09417 4	2	6
9418	2" (50mm) Black - Stem 02	75lb (34kg)	09418 1	2	6
▶ 9419	2" (50mm) Black - Stem 82	75lb (34kg)	09419 8	2	6
★ 9672	2" (50mm) Black - Stem 07	75lb (34kg)	09672 7	1	6
★ 9673	2" (50mm) Black - Stem 87	75lb (34kg)	09673 4	1	6
★ 9674	2" (50mm) Black - Stem 82	75lb (34kg)	09674 1	1	6
★ 9679	2" (50mm) Bright Chrome - Stem 82	75lb (34kg)	09679 6	1	6
9694	2" (50mm) Black - Stem 88	75lb (34kg)	09694 9	1	6
▶ 9428	2-1/2" (64mm) Black Soft Tread - Stem 88	<i>HSF</i> 75lb (34kg)	09428 0	1	4

★ Not Stocked in Canada – Call for Lead-time
 ▶ Available Only in Canada

HSF For Hard Surface Floors

»» Twin Wheels Casters - Bulk

ITEM #	DESCRIPTION	LOAD CAP LB (KG)	U.P.C. (0 39003)	PCS/ CTN
★ 9733	2" (50mm) Black - Stem 07	75lb (34kg)	09733 5	24
★ 9741	2" (50mm) Black - Stem 88	75lb (34kg)	09741 0	24

★ Not Stocked in Canada – Call for Lead-time



BED ROLLERS & FURNITURE SOCKETS

For wood or metal bed frames. Provides easy movement and maximum floor protection by distributing weight over larger area. Adjustable bed casters utilize the wasted space beneath your bed and will safely accommodate storage boxes up to 10" high.

Wide Wheel Bed Rollers

ITEM #	DESCRIPTION		LOAD CAP LB (KG)	U.P.C. (0 39003)	PCS/ PKG	PKG/ CTN
▶ 9518	2-1/8" (54mm) Black w/Brake Soft Tread - Stem	HSF	125lb (57kg)	09518 8	2	6
9532	2-1/8" (54mm) 10" Adjustable Black Soft Tread - Stem	HSF	125lb (57kg)	09532 4	2	4
9535	2-1/8" (54mm) White - Stem		125lb (57kg)	09535 5	2	6
9536	2-1/8" (54mm) White w/Brake - Stem		125lb (57kg)	09536 2	2	6

▶ Available Only in Canada



HSF For Hard Surface Floors

3" x 3" rubber cups or clear spiked plastic cups that fit beneath bed casters are available on page 33.

Metal and plastic sockets designed to accommodate bed glides and hold standard stem fastenings in tubular furniture.

Furniture Sockets

ITEM #	DESCRIPTION		LOAD CAP LB (KG)	U.P.C. (0 39003)	PCS/ PKG	PKG/ CTN
9439	3/8" (10mm) I.D. Metal		N/A	09439 6	4	6
▶ 9440	3/8" (10mm) I.D. Plastic Bed Frame		N/A	09440 2	4	6
9064	1/2" (13mm) I.D. Plastic		N/A	09064 0	4	6
9066	5/8" (16mm) I.D. Plastic		N/A	09066 4	4	6
9069	3/4" (19mm) I.D. Plastic		N/A	09069 5	4	6
★ 9071	7/8" (22mm) I.D. Plastic		N/A	09071 8	4	6
★ 9073	1" (25mm) I.D. Plastic		N/A	09073 2	4	6

★ Not Stocked in Canada – Call for Lead-time

▶ Available Only in Canada

Appliance casters and rollers easily move refrigerators, and other heavy appliances. Not recommended for use on cushioned vinyl floors.

Appliance Casters & Rollers

ITEM #	DESCRIPTION	LOAD CAP LB (KG)	U.P.C. (0 39003)	PCS/ PKG	PKG/ CTN
9441	7/8" (22mm) White Dual Wheels - Threaded Stem - Caster	250lb (114kg)	09441 9	4	6
9601	Stamped Steel Rollers Adjustable Length 18.25" - 25" (46 - 63.5cm)	1200lb (545kg)	09601 7	2	10
★ 9603	Aluminum Rollers Adjustable Length 18.25" - 28" (46 - 71cm)	2000lb (907kg)	09603 1	2	5
9848	Plastic Rollers 19" x 28" (48.3 x 63.5cm)	1200lb (545kg)	09848 6	2	10

★ Not Stocked in Canada – Call for Lead-time



LIGHT DUTY & MEDIUM DUTY

Plastic Wheel. Economical stem or plate mount casters for use on light weight furniture, cribs, playpens, coffee and bedside tables. Rolls on carpeted and hard floors. Swivel on acetal resin bearings.

Wood. A decorative hardwood wheel caster perfectly suited for antiques.

»» Economical Light Duty Casters

ITEM #	DESCRIPTION	LOAD CAP LB (KG)	U.P.C. (0 39003)	PCS/ PKG	PKG/ CTN
9052	1-1/4" (32mm) White - Plate 1-3/16" x 1-3/4" (30 x 44mm) Rectangular	40lb (18kg)	09052 7	4	6
9053	1-1/4" (32mm) White - Stem 02	40lb (18kg)	09053 4	4	6
9556	1-1/4" (32mm) Black - Plate 1-3/16" x 1-3/4" (30 x 44mm) Rectangular	40lb (18kg)	09556 0	4	6
9557	1-1/4" (32mm) Black - Stem 02	40lb (18kg)	09557 7	4	6
9054	1-5/8" (40mm) White - Plate 1-3/16" x 1-3/4" (30 x 44mm) Rectangular	50lb (23kg)	09054 1	4	6
9055	1-5/8" (40mm) White - Stem 02	50lb (23kg)	09055 8	4	6
9558	1-5/8" (40mm) Black - Plate 1-3/16" x 1-3/4" (30 x 44mm) Rectangular	50lb (23kg)	09558 4	4	6
9559	1-5/8" (40mm) Black - Stem 02	50lb (23kg)	09559 1	4	6
★ 9040	2" (50mm) White - Stem 04	60lb (27kg)	09040 4	2	6
★ 9041	2" (50mm) White - Plate 1-3/16" x 2" (30 x 50mm) Rectangular	60lb (27kg)	09041 1	2	6

★ Not Stocked in Canada – Call for Lead-time

»» Wood Casters

ITEM #	DESCRIPTION	LOAD CAP LB (KG)	U.P.C. (0 39003)	PCS/ PKG	PKG/ CTN
★ 9051	1-5/8" (40mm) Wood - Stem 02	35lb (16kg)	09051 0	2	6

★ Not Stocked in Canada – Call for Lead-time



MEDIUM DUTY

Industry standard for wood base office furniture. Double ball-bearing construction allow for instant swiveling. It has a black soft rubber wheel for smooth, silent operation on hard floors and chair mats.

»» Medium Duty Casters

ITEM #	DESCRIPTION	LOAD CAP LB (KG)	U.P.C. (0 39003)	PCS/ PKG	PKG/ CTN
9347	1-5/8" (40mm) Rubber - Stem 02	<i>HSF</i> 70lb (32kg)	09347 4	2	6
★ 9348	1-5/8" (40mm) Rubber - Plate 13	<i>HSF</i> 70lb (32kg)	09348 1	2	6
9345	2" (50mm) Rubber - Stem 02	<i>HSF</i> 80lb (36kg)	09345 0	2	6
9346	2" (50mm) Rubber - Plate 13	<i>HSF</i> 80lb (36kg)	09346 7	2	6
★ 9188	BULK: 1-5/8" (40mm) Stem 02 Medium Duty Antique Copper	70lb (32kg)	09188 3		24

★ Not Stocked in Canada – Call for Lead-time

HSF For Hard Surface Floors

MEDIUM DUTY (cont'd)

Double ball bearing construction assures easy swiveling for heavy furniture, appliances, equipment, or point-of-purchase displays. Friction grip stem can fit directly into cast aluminum, molded plastic, or pressed steel chair bases.



Friction Grip Ring Medium Duty Casters

ITEM #	DESCRIPTION	LOAD CAP LB (KG)	U.P.C. (0 39003)	PCS/ PKG	PKG/ CTN
★ 9688	2-1/2" (64mm) Polyolefin - Stem 82	100lb (45kg)	09688 8	1	6

★ Not Stocked in Canada – Call for Lead-time

Double ball bearing design assures easy swiveling for metal furniture, carts, racks, appliances and more.

Threaded Stem Medium Duty Casters

ITEM #	DESCRIPTION	LOAD CAP LB (KG)	U.P.C. (0 39003)	PCS/ PKG	PKG/ CTN
9344	2" (50mm) Rubber - Stem 07	<i>HSF</i> 80lb (36kg)	09344 3	2	6

HSF For Hard Surface Floors

G1 Series CASTERS

Two inch casters use a TPU (Thermoplastic Polyurethane) wheel and three inch casters use a TPR (Thermoplastic Rubber) wheel. Both sizes have a durable, soft, non-marking wheel that combines quiet movement with superior floor protection.

G1 General Duty Casters

ITEM #	DESCRIPTION	LOAD CAP LB (KG)	U.P.C. (0 39003)	PKG/ CTN
▶ 3541	2" (50mm) TPU Wheel - Swivel	88lb (40kg)	03541 2	24
▶ 3542	2" (50mm) TPU Wheel - Swivel with Brake	88lb (40kg)	03542 9	24
▶ 3543	2" (50mm) TPU Wheel - Rigid	88lb (40kg)	03543 6	24
▶ 3545	3" (75mm) TPR Wheel - Swivel	121lb (55kg)	03545 0	10
▶ 3546	3" (75mm) TPR Wheel - Swivel with Brake	121lb (55kg)	03546 7	10
▶ 3547	3" (75mm) TPR Wheel - Rigid	121lb (55kg)	03547 4	10

▶ Available Only in Canada

SOFT RUBBER

Soft rubber wheels give mobility to heavy loads on smooth hard surface and finished concrete floors where quiet movement and floor protection are major considerations.

SAFE WITH	ACID	NO	FLOORING SURFACE	CARPETS	YES
	HEAT	NO		CERAMICS	YES
	OIL	NO		CONCRETE	YES
	WATER	NO		WOOD	YES

General Duty - Swivel

ITEM #	DESCRIPTION	LOAD CAP LB (KG)	U.P.C. (0 39003)	PCS/ CTN
9487	1-1/4" (32mm)	30lb (14kg)	09487 7	50
9489	1-1/2" (38mm)	40lb (18kg)	09489 1	30
9477	2" (50mm)	90lb (41kg)	09477 8	30
9509	2" (50mm) w/Side Brake	90lb (41kg)	09509 6	20
9478	2-1/2" (64mm)	100lb (45kg)	09478 5	10
9510	2-1/2" (64mm) w/Side Brake	100lb (45kg)	09510 2	10
9479	3" (75mm)	175lb (80kg)	09479 2	10
9511	3" (75mm) w/Side Brake	175lb (80kg)	09511 9	10
9480	4" (100mm)	225lb (103kg)	09480 8	5
9512	4" (100mm) w/Side Brake	225lb (103kg)	09512 6	5
9787	5" (125mm)	200lb (91kg)	09787 8	4
9788	5" (125mm) w/Side Brake	200lb (91kg)	09788 5	4
▶ 9491	6" (150mm)	225lb (103kg)	09491 4	4
▶ 9508	6" (150mm) w/Side Brake	225lb (103kg)	09508 9	4

▶ Available Only in Canada

General Duty - Rigid

ITEM #	DESCRIPTION	LOAD CAP LB (KG)	U.P.C. (0 39003)	PCS/ CTN
9488	1-1/4" (32mm)	30lb (14kg)	09488 4	50
9490	1-1/2" (38mm)	40lb (18kg)	09490 7	12
9481	2" (50mm)	90lb (41kg)	09481 5	16
9482	2-1/2" (64mm)	100lb (45kg)	09482 2	8
9483	3" (75mm)	175lb (80kg)	09483 9	8
9484	4" (100mm)	225lb (103kg)	09484 6	5
9789	5" (125mm)	200lb (91kg)	09789 2	4
▶ 9492	6" (150mm)	225lb (103kg)	09492 1	4

▶ Available Only in Canada

General Duty - Threaded Stem

ITEM #	DESCRIPTION	LOAD CAP LB (KG)	U.P.C. (0 39003)	PCS/ PKG	PKG/ CTN
9496	3" (75mm) w/Side Brake - Stem 3/8" x 16 x 1-1/2" (10mm x 16 x 38mm)	150lb (69kg)	09496 9	1	4

Ideal for pianos and equipment. Combines high load capacity with excellent mobility and floor protection. Full double ball-bearing construction provides easy swiveling and long service life.

Dual Wheel Casters

ITEM #	DESCRIPTION	LOAD CAP LB (KG)	U.P.C. (0 39003)	PCS/ CTN
★ 9048	2" (50mm) Swivel - Copper Oxide Plate	160lb (73kg)	09048 7	40

★ Not Stocked in Canada – Call for Lead-time



SOFT RUBBER (cont'd)

Friction Grip Ring Casters

ITEM #	DESCRIPTION	LOAD CAP LB (KG)	U.P.C. (0 39003)	PCS/ CTN
★ 9191	2-1/2" (64mm) - Stem 87	100lb (45kg)	09191 3	12
★ 9192	2" (50mm) – Stem 7/16" x 1-7/8" (11 x 48mm)	80lb (36kg)	09192 0	24
9193	2" (50mm) – Stem 7/16" x 1-3/8" (11 x 35mm)	80lb (36kg)	09193 7	24
9197	2-1/2" (64mm) – Stem 7/16" x 1-7/8" (11 x 48mm)	85lb (39kg)	09197 5	12

★ Not Stocked in Canada – Call for Lead-time

Threaded Stem Casters

ITEM #	DESCRIPTION	LOAD CAP LB (KG)	U.P.C. (0 39003)	PCS/ CTN
9194	2" (50mm) - Stem 3/8" x 16 x 1-1/2" (10mm x 16 x 38mm)	80lb (36kg)	09194 4	24
9195	3" (75mm) - Stem 3/8" x 16 x 1-1/2" (10mm x 16 x 38mm)	90lb (41kg)	09195 1	12
9196	4" (100mm) - Stem 1/2" x 13 x 1-1/2" (13mm x 13 x 38mm)	115lb (52kg)	09196 8	6
▶ 9034	4" (100mm) w/brake - Stem 1/2" x 1-1/2" (13mm x 38mm)	115lb (52kg)	09034 3	6
▶ 9189	3" (75mm) w/brake- Stem 3/8" x 1-1/2" (10mm x 38mm)	110lb (50kg)	09189 0	12
▶ 9190	2" (50mm) w/brake - Stem 3/8" x 1-1/2" (10mm x 38mm)	80lb (36kg)	09190 6	24

▶ Available Only in Canada









Recommended for tool boxes, bakery racks, dollies, stock trucks, hotel trucks, and other institutional uses requiring good mobility.

Light Medium Duty Casters - Series 400

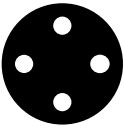
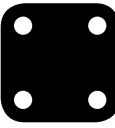
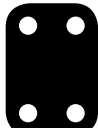
ITEM #	DESCRIPTION	LOAD CAP LB (KG)	U.P.C. (0 39003)	PCS/ CTN
★ 9629	4" (100mm) - Swivel	200lb (91kg)	09629 1	10
★ 9630	4" (100mm) – Swivel w/Brake	200lb (91kg)	09630 7	10
★ 9659	4" (100mm) – Rigid	200lb (91kg)	09659 8	10

★ Not Stocked in Canada – Call for Lead-time



CASTER FASTENERS											
	02 Stem 5/16" x 1-1/2"		05 Stem 3/8" x 1-1/2"		82 Stem 7/16" x 1-7/16"		Round Plate 11/16"		01 Plate 1-1/2" SQ.		13 Plate 1-1/8" x 2"
	04 Stem 3/8" x 1-1/2"		07 Stem 5/16" x 1"		87 Stem 3/8" x 1"						18 Plate 1-1/2" x 2-1/8"
	45 Stem 5/16" x 7/8"		88 Stem 7/16" x 7/8"								
STEMS			PLATES								

SOFT RUBBER

SAFE WITH	ACID	NO	FLOORING SURFACE	CARPETS	YES
	HEAT	NO		CERAMICS	YES
	OIL	NO		CONCRETE	YES
	WATER	NO		WOOD	YES

Elastic Blue Rubber is a super elastic rubber wheel that instantly regains its original form when a force is applied to the caster. As friction is considerably reduced, initial starting thrust required by user is brought to a minimum. The softness of this wheel will allow for easier rolling over obstacles, excellent rolling quality and important noise reduction. Non-marking, its fantastic abrasion resistance will increase its durability compared to standard rubber wheel.

General Duty Casters - Swivel

ITEM #	DESCRIPTION	LOAD CAP LB (KG)	U.P.C. (0 39003)	PCS/ CTN
9260	4" (100mm)	265lb (120kg)	09260 6	5
9262	4" (100mm) w/Brake	265lb (120kg)	09262 0	5
▶ 9263	5" (125mm)	330lb (150kg)	09263 7	4
▶ 9265	5" (125mm) w/Brake	330lb (150kg)	09265 1	4

▶ Available Only in Canada

General Duty Casters - Rigid

ITEM #	DESCRIPTION	LOAD CAP LB (KG)	U.P.C. (0 39003)	PCS/ CTN
9261	4" (100mm)	265lb (120kg)	09261 3	5
9264	5" (125mm)	330lb (150kg)	09264 4	4

What are Total Lock Brakes?
Brakes that lock wheel and swivel simultaneously.



Semi Elastic Rubber wheel is primarily used in environments where noise reduction, durability and a superior rolling quality are required.

General Duty Casters - Swivel

ITEM #	DESCRIPTION	LOAD CAP LB (KG)	U.P.C. (0 39003)	PCS/ CTN
9285	3" (75mm)	130lb (60kg)	09285 9	5
9287	3" (75mm) w/Brake	130lb (60kg)	09287 3	5
▶ 9288	4" (100mm)	220lb (100kg)	09288 0	5
9290	4" (100mm) w/Brake	220lb (100kg)	09290 3	5

▶ Available Only in Canada

General Duty Casters - Rigid

ITEM #	DESCRIPTION	LOAD CAP LB (KG)	U.P.C. (0 39003)	PCS/ CTN
▶ 9286	3" (75mm)	130lb (60kg)	09286 6	10
9289	4" (100mm)	220lb (100kg)	09289 7	5

▶ Available Only in Canada

Thermoplastic Rubber (TPR)

TPR (Thermoplastic Rubber) offers resistance to oils and chemicals. It's soft non-marking surface wheel combines superior endurance with quiet mobility.

ITEM #	DESCRIPTION	LOAD CAP LB (KG)	U.P.C. (0 39003)	PCS/ CTN
▶ 9790	2" x 13/16" (50 x 21mm) Swivel 82 Stem	125lb (57kg)	09790 8	24
▶ 9807	3" x 13/16" (75 x 21mm) Swivel 82 Stem	175lb (80kg)	09807 3	12

▶ Available Only in Canada



9260
9263



9262
9265

9261
9264



9287
9290

9285
9288

9286
9289

9790
9807

HARD RUBBER

SAFE WITH	ACID	NO	FLOORING SURFACE	CARPETS	YES
	HEAT	YES		CERAMICS	YES
	OIL	YES		CONCRETE	YES
	WATER	NO		WOOD	YES

Hard rubber wheels are impervious to oils, greases and gasoline while combining many desirable characteristics: high load ratings, good mobility, high impact resistance, as well as excellent floor protection. Unlike other wheels, it does not develop flat spots under standing loads.

General Duty Casters- Swivel

ITEM #	DESCRIPTION	LOAD CAP LB (KG)	U.P.C. (0 39003)	PCS/ CTN
★ 9270	2" (50mm) Grey	125lb (57kg)	09270 5	50
★ 9271	2" (50mm) w/Side Brake Grey	125lb (57kg)	09271 2	50
★ 9273	2-1/2" (64mm) Grey	175lb (80kg)	09273 6	30
★ 9274	2-1/2" (64mm) w/Side Brake Grey	175lb (80kg)	09274 3	30
★ 9276	3" (75mm) Grey	210lb (95kg)	09276 7	20
★ 9277	3" (75mm) w/Side Brake Grey	210lb (95kg)	09277 4	20
★ 9279	4" (100mm) Grey	255lb (116kg)	09279 8	10
★ 9280	4" (100mm) w/Side Brake Grey	255lb (116kg)	09280 4	10

★ Not Stocked in Canada – Call for Lead-time

General Duty Casters - Rigid

ITEM #	DESCRIPTION	LOAD CAP LB (KG)	U.P.C. (0 39003)	PCS/ CTN
★ 9272	2" (50mm) Grey	125lb (57kg)	09272 9	50
★ 9275	2-1/2" (64mm) Grey	175lb (80kg)	09275 0	30
★ 9278	3" (75mm) Grey	210lb (95kg)	09278 1	20
★ 9281	4" (100mm) Grey	255lb (116kg)	09281 1	10

★ Not Stocked in Canada – Call for Lead-time



9270
9273
9276
9279



9271
9274
9277
9280

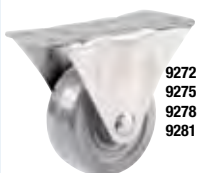

9272
9275
9278
9281

SAFE WITH	ACID	NO	FLOORING SURFACE	CARPETS	YES
	HEAT	YES		CERAMICS	YES
	OIL	YES		CONCRETE	YES
	WATER	NO		WOOD	YES

MOLD-ON RUBBER •Series 1400•

What is the 1400 series?

The difference between our general duty casters and the 1400 series mainly lies with the sturdier construction type. The top plate is made with 1/4" (6mm) cold forged steel. It allows for heavier load capacity. The wheel bearings are straight roller 3/4" (19mm) with spanner bushing.

Mold-on Rubber casters have a cushioned rubber tread bonded to cast iron core. These wheels absorb shock and vibration and are quiet during use. Ideal for most general medium-heavy duty industrial applications such as platform trucks, wire shelving, and other warehouse trucks and carts intended for commercial use.

Medium Heavy Duty Casters •Series 1400•

ITEM #	DESCRIPTION	LOAD CAP LB (KG)	U.P.C. (0 39003)	PCS/ CTN
3131	8" x 2" (200 x 50mm) Swivel	500lb (228kg)	03131 5	2
3133	8" x 2" (200 x 50mm) Rigid	500lb (228kg)	03133 9	2
9493	6" x 2" (150 x 50mm) Swivel	410lb (186kg)	09493 8	4
9494	6" x 2" (150 x 50mm) Rigid	410lb (186kg)	09494 5	4



3131
9493



3133
9494

MOLD-ON POLYURETHANE

•Series 1400•

Polyurethane wheels are durable, protect floors and resist oils and chemicals. Use for fixtures, carts, furniture, institutional and medical equipment.

SAFE WITH	ACID	YES	FLOORING SURFACE	CARPETS	YES
	HEAT	NO		CERAMICS	NO
	OIL	YES		CONCRETE	YES
	WATER	YES		WOOD	NO

▶▶▶ Mold-On Polyurethane on Polypropylene Hubs

ITEM #	DESCRIPTION	LOAD CAP LB (KG)	U.P.C. (0 39003)	PCS/ CTN
▶ 9422	6" x 2" (150 x 50mm) Red on Black Wheel - Swivel	900lb (408kg)	09422 8	4
▶ 9424	6" x 2" (150 x 50mm) Red on Black Wheel - Rigid	900lb (408kg)	09424 2	4

▶ Available Only in Canada

▶▶▶ Mold-On Polyurethane on Steel Hubs

ITEM #	DESCRIPTION	LOAD CAP LB (KG)	U.P.C. (0 39003)	PCS/ CTN
▶ 3164	4" x 2" (100 x 50mm) Mold On PU/Steel Hub - Swivel	700lb (317kg)	03164 3	4
▶ 3166	6" x 2" (150 x 50mm) Mold On PU/Steel Hub - Swivel	900lb (408kg)	03166 7	4
▶ 3167	8" x 2" (200 x 50mm) Mold On PU/Steel Hub - Swivel	700lb (317kg)	03167 4	2
▶ 3172	4" x 2" (100 x 50mm) Mold On PU/Steel Hub - Rigid	700lb (317kg)	03172 8	4
▶ 3174	6" x 2" (150 x 50mm) Mold On PU/Steel Hub - Rigid	900lb (408kg)	03174 2	4
▶ 3175	8" x 2" (200 x 50mm) Mold On PU/Steel Hub - Rigid	1000lb (454kg)	03175 9	2
▶ 9180	6" x 2" (150 x 50mm) Mold On PU/Steel Hub - Swivel w/Brake	900lb (408kg)	09108 7	4
▶ 9186	4" x 2" (100 x 50mm) Mold On PU/Steel Hub - Swivel w/Brake	700lb (317kg)	09186 9	4
▶ 9187	8" x 2" (200 x 50mm) Mold On PU/Steel Hub - Swivel w/Brake	1000lb (454kg)	09187 6	2

▶ Available Only in Canada



CAST IRON

SAFE WITH	ACID	YES	FLOORING SURFACE	CARPETS	NO
	HEAT	YES		CERAMICS	NO
	OIL	YES		CONCRETE	YES
	WATER	NO		WOOD	NO

Cast Iron wheels have an exceptionally long wear life; can withstand temperature extremes. Recommended for infrequently moved objects on rough wood and concrete floors.

▶▶▶ General Duty Casters - Swivel

ITEM #	DESCRIPTION	LOAD CAP LB (KG)	U.P.C. (0 39003)	PCS/ CTN
9174	2" (50mm)	125lb (57kg)	09174 6	12
★ 9176	2-1/2" (64mm)	175lb (80kg)	09176 0	6
★ 9780	3" (75mm)	250lb (114kg)	09780 9	4
★ 9782	4" (100mm)	500lb (228kg)	09782 3	4

★ Not Stocked in Canada – Call for Lead-time

▶▶▶ General Duty Casters - Rigid

ITEM #	DESCRIPTION	LOAD CAP LB (KG)	U.P.C. (0 39003)	PCS/ CTN
9182	2" (50mm)	125lb (57kg)	09182 1	24
★ 9184	2-1/2" (64mm)	175lb (80kg)	09184 5	12
★ 9781	3" (75mm)	250lb (114kg)	09781 6	4
★ 9783	4" (100mm)	500lb (228kg)	09783 0	4

★ Not Stocked in Canada – Call for Lead-time

SAFE WITH	ACID	YES	FLOORING SURFACE	CARPETS	YES
	HEAT	NO		CERAMICS	NO
	OIL	YES		CONCRETE	YES
	WATER	YES		WOOD	NO

POLYPROPYLENE

Polypropylene wheels are lightweight, non-marking wheels impervious to water with good chemical resistance. Long wearing and low in cost.



General Duty Casters - Swivel

ITEM #	DESCRIPTION	LOAD CAP LB (KG)	U.P.C. (0 39003)	PCS/ CTN
9392	2" (50mm)	125lb (57kg)	09392 4	36
9393	2-1/2" (64mm)	175lb (80kg)	09393 1	12
9394	3" (75mm)	210lb (95kg)	09394 8	8
★ 9395	4" (100mm)	200lb (91kg)	09395 5	4
★ 9541	CASTER BULK: 2" Swivel Plate w/Brake	125lb (57kg)	09541 6	30
★ 9543	CASTER BULK: 3" Swivel Plate w/Brake	210lb (95kg)	09543 0	20

★ Not Stocked in Canada – Call for Lead-time

General Duty Casters - Rigid

ITEM #	DESCRIPTION	LOAD CAP LB (KG)	U.P.C. (0 39003)	PCS/ CTN
9396	2" (50mm)	125lb (57kg)	09396 2	24
★ 9397	2-1/2" (64mm)	175lb (80kg)	09397 9	6
★ 9398	3" (75mm)	210lb (95kg)	09398 6	6
★ 9399	4" (100mm)	200lb (91kg)	09399 3	4

★ Not Stocked in Canada – Call for Lead-time

Medium Heavy Duty Casters •400 Series•

ITEM #	DESCRIPTION	LOAD CAP LB (KG)	U.P.C. (0 39003)	PCS/ CTN
★ 9784	CASTER BULK: 4" Swivel Plate 400 Series	275lb (125kg)	09784 7	4
★ 9786	CASTER BULK: 4" Rigid 400 Series	275lb (125kg)	09786 1	4

★ Not Stocked in Canada – Call for Lead-time

PHENOLIC

•Series 1400•

Phenolic makes a high strength, high impact wheel resistant to oil, gasoline, even dilute acids.

SAFE WITH	ACID	YES	FLOORING SURFACE	CARPETS	YES
	HEAT	YES		CERAMICS	NO
	OIL	YES		CONCRETE	YES
	WATER	YES		WOOD	NO

What is the 1400 series?

The difference between our general duty casters and the 1400 series mainly lies with the sturdier construction type. The top plate is made with 1/4" (6mm) cold forged steel. It allows for heavier load capacity. The wheel bearings are straight roller 3/4" (19mm) with spanner bushing.

»»» Heavy Duty Casters - Swivel •Series 1400•

ITEM #	DESCRIPTION	LOAD CAP LB (KG)	U.P.C. (0 39003)	PCS/ CTN
▶ 9770	4" (100mm)	500lb (228kg)	09770 0	4
9774	6" (150mm)	840lb (382kg)	09774 8	4
▶ 9778	6" x 2" (150 x 50mm) w/brake	840lb (382kg)	09778 6	4
▶ 9779	4" x 2" (100 x 50mm) w/brake	500lb (228kg)	09779 3	4

▶ Available Only in Canada

»»» Heavy Duty Casters - Rigid •Series 1400•

ITEM #	DESCRIPTION	LOAD CAP LB (KG)	U.P.C. (0 39003)	PCS/ CTN
▶ 9771	4" (100mm)	500lb (228kg)	09771 7	4
9775	6" (150mm)	840lb (382kg)	09775 5	4

▶ Available Only in Canada

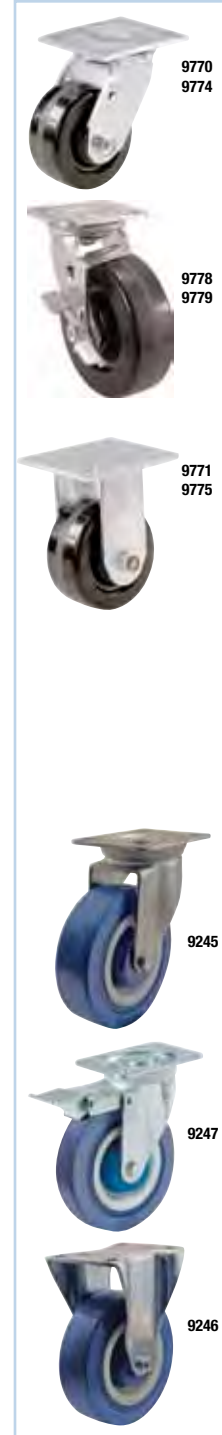

POLYAMIDE

SAFE WITH	ACID	NO	FLOORING SURFACE	CARPETS	YES
	HEAT	NO		CERAMICS	YES
	OIL	NO		CONCRETE	YES
	WATER	NO		WOOD	YES

Polyamide wheels combine the advantages of a hard polyamide band on top with a softer elastic rubber circle that acts as a shock absorber, reducing significantly damages to casters and assuring softer rolling quality. The hard polyamide band top maintains wheel maneuverability to the fullest even under heavy loads. This brings unbeatable quality with minimal starting thrust, greater ease in handling, important noise reduction, easier rolling over obstacles, improved durability and non-marking.

»»» General Duty Casters - Swivel

ITEM #	DESCRIPTION	LOAD CAP LB (KG)	U.P.C. (0 39003)	PCS/ CTN
9245	5" (125mm)	440lb (200kg)	09245 3	4
9247	5" (125mm) w/Brake*	440lb (200kg)	09247 7	4

*Brakes that lock wheel and swivel simultaneously.



»»» General Duty Casters - Rigid

ITEM #	DESCRIPTION	LOAD CAP LB (KG)	U.P.C. (0 39003)	PCS/ CTN
▶ 9246	5" (125mm)	440lb (200kg)	09246 0	4

▶ Available Only in Canada

PNEUMATIC

SAFE WITH	ACID	NO	FLOORING SURFACE	CARPETS	YES
	HEAT	NO		CERAMICS	YES
	OIL	NO		CONCRETE	YES
	WATER	YES		WOOD	YES

Pneumatic wheels give mobility to heavy loads on smooth hard surface and finished concrete floors. Recommended for the protection of both loads and floors.



Medium Heavy Duty Casters

ITEM #	DESCRIPTION	LOAD CAP LB (KG)	U.P.C. (0 39003)	PCS/ CTN
9794	8" (200mm) Swivel	220lb (100kg)	09794 6	4
9796	10" (250mm) Swivel	350lb (160kg)	09796 0	4
9795	8" (200mm) Rigid	220lb (100kg)	09795 3	4
9797	10" (250mm) Rigid	350lb (160kg)	09797 7	4

Gate caster has a spring loaded universal bracket for use on wood or chain link fences. Hard rubber tread on #9785 does not develop flat spots under standing load and supports gate weights up to 125 lbs. Larger #9798 supports gate weights of 200 lbs.

Gate Caster

ITEM #	DESCRIPTION	LOAD CAP LB (KG)	U.P.C. (0 39003)	PCS/ CTN
9785	Spring Loaded 4" (100mm) Hard Rubber Wheel	125lb (57kg)	09785 4	6
9798	Spring Loaded 8" (200mm) Pneumatic Wheel	200lb (91kg)	09798 4	4

REPLACEMENT WHEELS

Multi-Purpose Replacement. An expanded selection of the most commonly used household, industrial, lawn/garden and material handling wheels. The line includes economical rust free plastic hubs, sturdy ball bearing steel hubs for more demanding applications, and pneumatic tires.

►►► Metal Hub Semi-Pneumatic Rubber Tires

ITEM #	DESCRIPTION	BORE	U.P.C. (0 39003)	PCS/ CTN
3339	7" x 1-1/2" (175 x 38mm) Ribbed Tread - 1/2" (13mm) bore	OFF	03339 5	12
3345	6" x 1-1/2" (150 x 38mm) Diamond Tread - 1/2" (13mm) bore Solid Tire	OFF	03345 6	12
3346	8" x 1-3/4" (200 x 44mm) Diamond Tread - 1/2" (13mm) bore Solid Tire	OFF	03346 3	—
3355	8" x 1-3/4" (200 x 44mm) Gear Tread - 1/2" (13mm) bore	OFF	03355 5	—
9584	12" x 1-3/4" (300 x 44mm) Ribbed Tread - 1/2" (13mm) bore	CTR	09584 3	6
9588	10" x 2-1/2" (250 x 64mm) Ribbed Tread - 5/8" (16mm) bore	OFF	09588 1	6
9589	6" x 1-1/2" (150 x 38mm) Diamond Tread - 1/2" (13mm) bore Grafoil bearing	OFF	09589 8	12
9590	6" x 1-1/2" (150 x 38mm) Ribbed Tread - 1/2" (13mm) bore	CTR	09590 4	12
9591	6" x 1-1/2" (150 x 38mm) Diamond Tread - 1/2" (13mm) bore	CTR	09591 1	12
9592	7" x 1-1/2" (175 x 38mm) Diamond Tread - 1/2" (13mm) bore	CTR	09592 8	12
★ 9593	7" x 1-1/2" (175 x 38mm) Diamond Tread - 1/2" (13mm) bore Grafoil bearing	OFF	09593 5	12
★ 9594	8" x 1-3/4" (200 x 44mm) Diamond Tread - 1/2" (13mm) bore	CTR	09594 2	12
9595	8" x 1-3/4" (200 x 44mm) Gear Tread - 1/2" (13mm) bore	CTR	09595 9	12
9596	10" x 1-3/4" (250 x 44mm) Ribbed Tread - 1/2" (13mm) bore	CTR	09596 6	6
9597	10" x 2-3/4" (250 x 70mm) Ribbed Tread - 5/8" (16mm) bore	CTR	09597 3	6
9598	8" x 2-1/2" (200 x 64mm) Ribbed Tread - 5/8" (16mm) bore	CTR	09598 0	6
9599	8" x 1-3/4" (200 x 44mm) Diamond Tread - 1/2" (13mm) bore Grafoil bearing	OFF	09599 7	12
★ 9636	8" x 1-3/4" (200 x 44mm) Ribbed Tread - 1/2" (13mm) bore	CTR	09636 9	12
9637	8" x 1-3/4" (200 x 44mm) Ribbed Tread - 5/8" (16mm) bore	CTR	09637 6	12
► 9702	7" x 1-1/2" (175 x 38mm) Ribbed Tread - 1/2" (13mm) bore	CTR	09702 1	12
► 9703	6" x 1-1/2" (150 x 38mm) Diamond Tread - 1/2" (13mm) bore	OFF	09703 8	12

★ Not Stocked in Canada – Call for Lead-time ► Available Only in Canada

Centered vs. Offset? (CTR-OFF)

Wheels with centered bore hubs are equal sizes on both sides of the wheel, and can be mounted in either position. Offset wheels have different sized hubs on the front and back sides and must be properly positioned for correct assembly.



►►► Plastic Hub Semi-Pneumatic Rubber Tires

ITEM #	DESCRIPTION	BORE	U.P.C. (0 39003)	PCS/ CTN
3350	14" x 1-3/4" (300 x 44mm) Plastic Spoke Wheel - 1/2" (13mm) bore	CTR	03350 0	6
9610	6" x 1-1/2" (150 x 38mm) Diamond Tread - 1/2" (13mm) bore	OFF	09610 9	12
9611	7" x 1-1/2" (175 x 38mm) Diamond Tread - 1/2" (13mm) bore	OFF	09611 6	12
9613	8" x 1-3/4" (200 x 44mm) Diamond Tread - 1/2" (13mm) bore	OFF	09613 0	12
9614	8" x 1-3/4" (200 x 44mm) Gear Tread - 1/2" (13mm) bore	OFF	09614 7	12
9615	10" x 1-3/4" (250 x 44mm) Diamond Tread - 1/2" (13mm) bore	OFF	09615 4	6

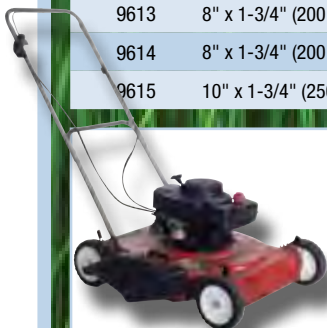

9589, 9592, 9599



9593



9584, 9596



9588, 9636



9597



9598



9702, 9703



9590, 9591, 9594

REPLACEMENT WHEELS

Flat Free Tires Never Require Maintenance

- Provides an air like ride, but can withstand all the common objects that typically cause flats.
- Eliminates ALL downtime related to flat tires.
- Lasts 4 to 10 times longer than standard air filled tires.



Flat Free Tires

ITEM #	DESCRIPTION	BORE	U.P.C. (0 39003)	PCS/ CTN
9704	10" x 3" (250 x 75mm) Sawtooth Tread - 5/8" (16mm) bore	OFF	09704 5	4
9708	15.1 x 3.74" (385 x 95mm) Knobby Tread - 5/8" (16mm) bore	CTR	09708 3	4
9709	14.33" x 3.10" (364 x 78mm) Ribbed Tread - Universal fit w/spacers & bushings	CTR	09709 0	4

Hand Truck Replacements Wheels

ITEM #	DESCRIPTION	BORE	U.P.C. (0 39003)	PCS/ CTN
9600	8" x 2-1/2" - 5/8" Bore Solid Cushioned Rubber, polypropylene hub. Ball bearings	OFF	09600 0	4
9602	10" x 2-1/2" - 5/8" Bore Solid Cushioned Rubber, polypropylene hub. Ball bearings	OFF	09602 4	4
9653	12" x 2-5/8" (300 x 66mm) Ribbed Tread - 3/4" (19mm) bore	CTR	09653 6	4
9654	12" x 2-5/8" (300 x 66mm) Ribbed Tread - 5/8" (16mm) bore	CTR	09654 3	4

Pneumatic Wheel - Ball Bearings

ITEM #	DESCRIPTION	BORE	U.P.C. (0 39003)	PCS/ CTN
3335	10" (250mm) w/350 x 4" 2 Ply Tire 4" Rim 5/8" (16mm) bore	OFF	03335 7	6
9634	10" (250mm) 4.10-10" x 3.5" 4 ply 50 PSI Sawtooth Tread 5/8" (16mm) bore	OFF	09634 5	—
9792	8" (200mm) 19-8 X 2.5 4 ply centered bore	CTR	09792 2	4
9793	10" (250mm) 19-10 X 3.5 4 ply centered 5/8" (16mm) bore	CTR	09793 9	4

Wheelbarrow Wheels

ITEM #	DESCRIPTION	BORE	U.P.C. (0 39003)	PCS/ CTN
3334	16" (400mm) 480/400 x 8" Ribbed Tread Tubeless Tire	CTR	03334 0	4
3336	16" (400mm) 480/400 x 8" 2 Ply Ribbed Tread Tubeless Tire	CTR	03336 4	4
3337	13" (330mm) 400 x 6" 2 Ply Ribbed Tread Tubeless Tire	CTR	03337 1	6
★ 9606	16" (400mm) Ball Bearings Ribbed Tread - 5/8" (16mm) bore	CTR	09606 2	4



★ Not Stocked in Canada – Call for Lead-time

Inner Tubes & Tires only

ITEM #	DESCRIPTION	BORE	U.P.C. (0 39003)	PCS/ CTN
3330	410/350 x 6" Inner tube L-Shape Valve Stem for 6" Rim	—	03330 2	6
3331	410/350 x 4" Inner tube L-Shape Valve Stem for 4" Rim	—	03331 9	6
3332	15/600 x 6" Replacement Inner tube L-Shape Valve Stem for 6" Rim	—	03332 6	6
3333	16" (400mm) Wheelbarrow Wheel 480/400 x 8" Tube & Tire only for 8" Rim (fits 9606)	—	03333 3	—
3338	16" (400mm) 480/400 x 8" 2 Ply Ribbed Tread Tire for 8" Rim	—	03338 8	—
3340	13" (330mm) 400 x 6" 2 Ply Ribbed Tread Replacement Tire for 6" Rim	—	03340 1	—
9612	480/400-8 inner tube straight valve stem for 8" rim	—	09612 3	6



How to Measure Tires

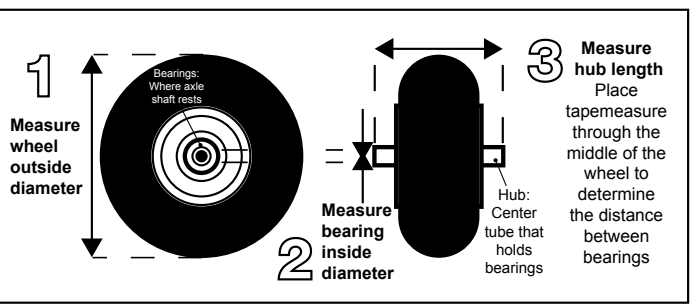

DOLLIES & TRUCKS

Movers Dolly. Adds mobility to heavy, bulky items in the basement, garage, or patio.

Platform Trucks. Multi-purpose fold down handle platform cart. Easy to use.

Snowmobile Dollies. Supports snowmobiles skids and back for added mobility across hard surface floors.

Tri-Dollies. Moves things easily. Tough polyolefin wheels swivel easily on steel ball bearings.

Wire Planter Dollies. For indoor use. Enables easy movement of pots and heavy items. Polished chrome finish.

»»» Movers Dolly w/Three inch Rubber Wheels

ITEM #	DESCRIPTION	LOAD CAP LB (KG)	U.P.C. (0 39003)	PCS/ PKG	PKG/ CTN
9850	20" x 31" (50 x 77cm)	840lb (380kg)	09850 9	1	4



9850

»»» Platform Trucks

ITEM #	DESCRIPTION	LOAD CAP LB (KG)	U.P.C. (0 39003)	PCS/ PKG	PKG/ CTN
▶ 9846	24" x 36" (60 x 90cm)	600lb (273kg)	09846 2	1	1
▶ 9847	19" x 29" (48 x 74cm)	330lb (150kg)	09847 9	1	1



9846
9847

▶ Available Only in Canada

»»» Tri-Dollies

ITEM #	DESCRIPTION	LOAD CAP LB (KG)	U.P.C. (0 39003)	PCS/ PKG	PKG/ CTN
9299	6" (150mm)	200lb (91kg)	09299 6	1	6
9442	12" (300mm)	300lb (136kg)	09442 6	1	6



9299
9442

»»» Plant Dollies

ITEM #	DESCRIPTION	LOAD CAP LB (KG)	U.P.C. (0 39003)	PCS/ PKG	PKG/ CTN
★ 8199	11-1/4" (285mm) Wire Dolly Chrome Finish	120lb (55kg)	08199 0	1	4
★ 9854	12.5" x 18.25" (32 x 46cm) Solid Wood Top Plant Dolly	360lb (163kg)	09854 7	1	5
			U.P.C. (6 89112)		
▶ 8199W	11-1/4" (285mm) Chrome Finish	120lb (55kg)	08199 6	1	4

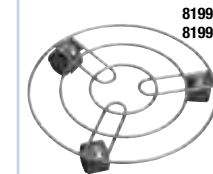

8199
8199W



9854

★ Not Stocked in Canada – Call for Lead-time
▶ Available Only in Canada

»»» Snowmobile Dolly Set

ITEM #	DESCRIPTION	LOAD CAP LB (KG)	U.P.C. (0 39003)	PCS/ PKG	PKG/ CTN
9298	Strong steel plate design with hard rubber casters	990lb (450kg)	09298 9	3	2

- Three piece unit enables minimal clearance turning to safely maneuver snowmobile in your storage area
- Heavy Duty steel with rust-resistant powder-coated finish
- Includes (A) two 7-1/8" x 7-3/4" front dollies (grooved for snowmobile skis) and (B) one 7-1/8" x 7-1/8" rear dolly



9298

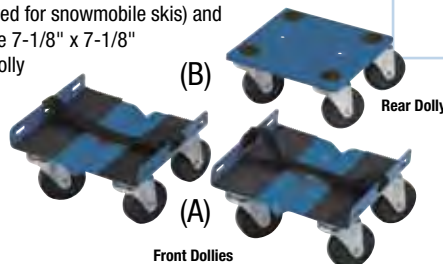

HOOK & LOOP PRODUCT LINE

NEW



Hook & Loop: Pads, Fasteners, Tapes and Wrap Ties

- Durable and Cost Effective
- Countless Uses - Home, Hobby, Office, Garage
- Easy to Use



ITEM #	DESCRIPTION	U.P.C. (0 39003)	PCS/ PKG	PKG/ CTN
4952	7/8" (22mm) - white round	04952 5	12/12	6
4953	7/8" (22mm) - black round	04953 2	12/12	6
4963	1" x 11-3/4" (25 x 300mm) - white tape	04963 1	1/1	6
4964	1" x 11-3/4" (25 x 300mm) - black tape	04964 8	1/1	6
4978	1/2" x 8" (12 x 200mm) - black straps	04978 5	5	6
4980	1/2" x 4" (12 x 110mm) - black straps	04980 8	5	6

Ideal for your home, hobby, garage, office use.

HEAVY DUTY FELT

For Wooden legs. These glides tap into wooden legs, will not split the wood and the heavy duty felt base protect hard surfaces and slides easily over floors that can be marred by most other glides.

Self-leveling felt is ideal for angled leg chairs. It's thick foam layer allows for superior surface adherence and grips better than other heavy duty felt pads available.



Heavy Duty Nail-On Felt Pads

ITEM #	DESCRIPTION	U.P.C. (0 39003)	PCS/ PKG	PKG/ CTN
9933	7/8" (22mm) w/Hollow Nail Almond	09933 9	8	6
9934	1" (25mm) w/Hollow Nail Almond	09934 6	8	12
9935	1-1/2" (38mm) w/Hollow Nail Almond	09935 3	4	12
▶ 9936	Dinette Set Value Pack Almond 16 – 1" (25mm) 4 – 1-1/2" (38mm)	09936 0	20 16 4	12
9938	1" (25mm) Brass Swivel Glide Almond	09938 4	4	6
▶ 9910	7/8" (22mm) w/Nail Brown	09910 0	8	12
▶ 9911	1-1/2" (38mm) w/Nail Brown	09911 7	4	12
▶ 9918	1" (25mm) w/Nail Brown	09918 6	8	12
▶ 9939	Dinette Set Value Pack 16 – 1" (25mm) 4 – 1-1/2" (38mm)	09939 1	20 16 4	12

★ Not Stocked in Canada – Call for Lead-time

▶ Available Only in Canada



Heavy Duty Felt Pad Cups

ITEM #	DESCRIPTION	U.P.C. (0 39003)	PCS/ PKG	PKG/ CTN
9824	Value pack combination of 9825 & 9826 Heavy Duty Felt Pad Furniture Cups Round /4 pcs 1-1/2" (38mm) + 16 pcs of 1" (25mm)	09824 0	20	6
9825	1" (25mm) Heavy Duty Felt Pad Furniture Cups Round	09825 7	4	6
9826	1-1/2" (38mm) Heavy Duty Felt Pad Furniture Cups Round	09826 4	4	6
9827	2" (50mm) Heavy Duty Felt Pad Furniture Cups Round	09827 1	4	6
★ 9828	2-1/2" (64mm) Heavy Duty Felt Pad Furniture Cups Round	09828 8	4	6
★ 9829	1-1/2" (38mm) Heavy Duty Felt Pad Furniture Cups Square	09829 5	4	6
▶ 9830	2-1/2" (64mm) Heavy Duty Felt Pad Furniture Cups Round Square	09830 1	4	6
▶ 9831	1-1/2" x 4" (38 x 100mm) Heavy Duty Felt Pad Furniture Cups Rectangle	09831 8	4	6

★ Not Stocked in Canada – Call for Lead-time

▶ Available Only in Canada



Self-leveling felt is ideal for angled leg chairs. It's thick foam layer allows for superior surface adherence and grips better than other heavy duty felt pads available. Corrects uneven wear of 3/8" or less on furniture.

Heavy Duty Self-Leveling FeltGard® Pads

ITEM #	DESCRIPTION	U.P.C. (0 39003)	PCS/ PKG	PKG/ CTN
▶ 9914	Combo pack of 9915 and 9916 – Leveling felt	09914 8	24	6
9915	1" (25mm) Self-Leveling Pads	09915 5	8	6
9916	1-1/2" (38mm) Self-Leveling Pads	09916 2	4	6

▶ Available Only in Canada



Heavy Duty Threaded Stem FeltGard® Pads

ITEM #	DESCRIPTION	U.P.C. (0 39003)	PCS/ PKG	PKG/ CTN
★ 9908	1" (25mm) Threaded Stem 1/4" x 20 x 1" (7mm x 20 x 25mm) Glide	09908 7	4	6
★ 9909	1-1/2" (38mm) Threaded Stem 1/4" x 20 x 1" (7mm x 20 x 25mm) Glide	09909 4	4	6



★ Not Stocked in Canada — Call for Lead-time

HEAVY DUTY FELT (cont'd)

**FELT
GARD**

Plus

Best On the Floor!

NEW



Hollow nail tap-in base with replaceable felt pads provides superior holding strength on wood furniture



3633
3634
3635

3636
3637
3638

9431

9369

9140, 9407
9408

9141

9142

Heavy Duty FeltGard® Plus Snap-on/Snap-Off Pads*

Snap-On Snap-Off felt caps are easy to install and then quickly removed and replaced when worn! Felt attaches to base without adhesive and will not fall off when moved. Replacement pads sold separately.

ITEM #	DESCRIPTION	U.P.C. (0 39003)	PCS/ PKG	PKG/ CTN
3633	7/8" (22mm) Round Pads	03633 4	8/8	6
3634	1" (25mm) Round Pads	03634 1	8/8	6
3635	1-1/2" (38mm) Round Pad	03635 8	4/4	6
3636	7/8" (22mm) Replacement Pads Only	03636 5	8	6
3637	1" (25mm) Replacement Pads Only	03637 2	8	6
3638	1-1/2" (38mm) Round Pad	03638 9	4	6

* Patent pending

Heavy Duty FeltGard® Plus Mover Pads

ITEM #	DESCRIPTION	U.P.C. (0 39003)	PCS/ PKG	PKG/ CTN
9431	5-3/4" x 8-1/4" (146 x 208mm) Mover Pads	09431 0	4	6
★ 9369	3" x 3" (75 x 75mm) Square Mover Pad	09369 6	4	6

★ Not Stocked in Canada – Call for Lead-time

Heavy Duty FeltGard® Plus Slider Pads

Large sized slider pads are made with premium quality felt backed by durable foam for repeated use on hard surface floors. Use, then remove and store until needed again.

ITEM #	DESCRIPTION	U.P.C. (0 39003)	PCS/ PKG	PKG/ CTN
9140	5" (125mm) Rounds Pads	09140 1	4	4
9141	2-1/2" x 9" (64 x 225mm) Rectangular Pads	09141 8	4	4
9142	4" x 7" (100 x 175mm) Pad	09142 5	4	4
9407	3-1/2" (89mm) Rounds Pads	09407 5	4	4
9408	2-1/2" (64mm) Self-Adhesive Pads	09408 2	4	4

HEAVY DUTY FELT



Super Stick **FELT GARD®** with hook & loop pads and sheets are specially designed for hard to attach applications on furniture where standard felt fails. Each package provides everything necessary for easy installation.

Self-Adhesive **FELT GARD®** pads are simple to install and offer protection for surfaces such as hardwood, linoleum, vinyl, asphalt tile, terrazzo, marble, etc.



»» Felt with Hook & Loop

ITEM #	DESCRIPTION	U.P.C. (0 39003)	PCS/ PKG	PKG/ CTN
▶ 9870	4-1/4" x 6" (108 x 150mm) Rectangle Sheet w/Hook & Loop	09870 7	1	6
▶ 9892	1-1/2" (38mm) Round Pads w/Hook & Loop	09892 9	4	6
▶ 9930	1" (25mm) Round Pads w/Hook & Loop	09930 8	16	6
▶ 9931	3/4" (19mm) Round Pads w/Hook & Loop	09931 5	20	6

▶ Available Only in Canada

»» Heavy Duty Adhesive Felt Pads

ITEM #	DESCRIPTION	U.P.C. (0 39003)	PCS/ PKG	PKG/ CTN
9815	1" (25mm) Square H-Duty Felt	09815 8	16	12
9816	1-1/2" x 1-1/2" (38 x 38mm) Corner H-Duty Felt	09816 5	8	12
9817	2" x 2" x 2-1/2" (50 x 50 x 64mm) Triangle H-Duty Felt	09817 2	4	12
9818	1/2" x 58" (13mm x 1.5m) H-Duty Felt Roll	09818 9	1	12
9819	1" Pad with Nylon Insert	09819 6	8	12
9844	1" x 3-3/4" (25mm x (95mm) Rectangle Pad	09844 8	4	12
▶ 9912PB	Big Value Pack Polybag 2 – 4-1/4" x 6" (108 x 150mm) Sheet 16 – 1" (25mm) Round Pads 8 – 1-1/2" (38mm) Round Pads	09912 4	26 2 16 8	12
▶ 9913	Dinette Pack 16 pcs of 1" (25mm) Pads & 4 pcs of 1-1/2" (38mm) Pads	09913 1	20	12
9927	2" (50mm) Pads	09927 8	4	6
9937	1/2" x 2-5/8" (13 x 67mm) Strip Pads	09937 7	16	12
9928	3" (75mm) Pads	09928 5	4	6
9947	Value Pack 1 – 4-1/4" x 6" (108 x 150mm) Sheet 10 – 3/4" (19mm) Round Pads 8 – 1" (25mm) Round Pads 4 – 1-1/2" (38mm) Round Pads 4 – 1/2" x 6" (13 x 150mm) Strips	09947 6	27 1 10 8 4 4	12
★ 9948	2" x 4" (50 x 100mm) Sheets	09948 3	3	12
9950	4-1/4" x 6" (108 x 150mm) Sheets	09950 6	2	12
9951	3/4" (19mm) Pads	09951 3	20	12
9952	1" (25mm) Pads	09952 0	16	12
9953	1-1/2" (38mm) Pads	09953 7	8	12
9954	1/2" x 6" (13 x 150mm) Strips	09954 4	9	12
9955	1-1/8" (29mm) Glide w/1" (25mm) Pads	09955 1	8	6
9972	1" (25mm) Pads Bonus Pack	09972 8	48	6
9976	1-1/2" (38mm) Pads Bonus Pack	09976 6	24	6

★ Not Stocked in Canada – Call for Lead-time

▶ Available Only in Canada



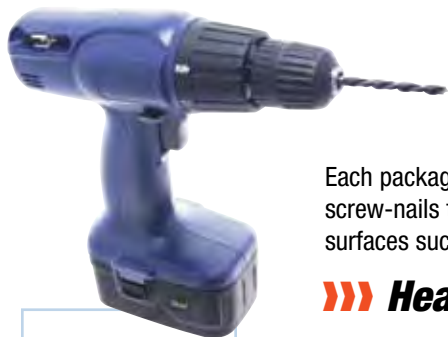

HEAVY DUTY FELT (cont'd)



Each package provides everything necessary for installation, including the drill bit and special screw-nails that can be either screwed or hammered in place. Intended for use on hard floor surfaces such as tile, linoleum, or wood.

Heavy Duty Felt Pads Packs includes Drill Bit & Screws

ITEM #	DESCRIPTION	U.P.C. (0 39003)	PCS/ PKG	PKG/ CTN
9840	3/4" (19mm) Round Pad	09840 0	8	6
9841	1" (25mm) Round Pad	09841 7	8	6
9842	1-1/2" (38mm) Round Pad	09842 4	4	6
9843	Value Pack 1" (25mm) & 1-1/2" (38mm) Combo	09843 1	20	4
9845	1" x 3-3/4" (25 x 95mm) Rectangle Pad	09845 5	4	6



ANTI-SKID PADS

SURFACE GRIP® non-skid pads are used to protect surfaces and minimize furniture movement while reducing noise and vibration. Heavy duty pads are ideal for furniture used on hard surfaces and the multi-purpose self-adhesive pads can be applied to small appliances or machinery in the home, office or garage.

Heavy Duty Anti-Skid Pads

ITEM #	DESCRIPTION	U.P.C. (0 39003)	PCS/ PKG	PKG/ CTN
9644	1" (25mm) Size Contains 4 Pads & 4 Screws per Card	09644 4	4	6
9645	1-1/2" (38mm) Size Contains 4 Pads & 4 Screws per Card	09645 1	4	6
9646	2" (50mm) Size Contains 4 Pads & 4 Screws per Card	09646 8	4	6
★ 9647	2-1/2" (64mm) Size Contains 4 Pads & 4 Screws per Card	09647 5	4	6

★ Not Stocked in Canada – Call for Lead-time



9644, 9645, 9646, 9647



3598, 3600



3601
3602
3603
3608
3627
3628
9970
9971



3616



3624



3615

Self-Adhesive Anti-Skid Pads

ITEM #	DESCRIPTION	U.P.C. (0 39003)	PCS/ PKG	PKG/ CTN
3598	2" x 4" Pads	03598 6	3	6
3600	4-1/4" x 6" Pads	03600 6	2	6
3601	3/4" Round Pads	03601 3	20	6
3602	1" Round Pads	03602 2	16	6
3603	1-1/2" Round Pads	03603 7	3	6
3608	2-1/2" Round Pads	03608 2	4	6
3615	1" Square Pads	03615 0	16	6
3616	1-1/2" x 1-1/2" "L" Shape Pads	03616 7	8	6
3624	1" x 3-3/4" Pads	03624 2	4	6
3627	2" Round Pads	03627 3	4	6
3628	3" Round Pads	03628 0	8	6
9970	1-1/2" (38mm) Round Pad	09970 4	8	12
9971	2" (50mm) Round Pad	09971 0	8	12

9970 & 9971 offer a thinner option than the standard product thickness of 3598-3628

SLIDE GLIDE®

SLIDEGLIDE®
Slide objects easily

Low Friction Sliders. Self-adhesive or screw-on glide, designed for use on all non-abrasive floor surfaces (low pile carpet, vinyl, etc.), and allows furniture or appliances to move smoothly over floors.

Self-Adhesive or Screw-In Pads

ITEM #	DESCRIPTION	U.P.C. (0 39003)	PCS/ PKG	PKG/ CTN
9219	1" (25mm) Chair Tip	09219 4	4	6
★ 9220	1-1/8"-1-1/4" (27-32mm) Chair Tip	09220 0	4	6
9221	1-3/4" (44mm) I.D. Cups	09221 7	4	6
9222	2-3/4" (70mm) I.D. Cups	09222 4	4	4
9240	1" (25mm) Square Pads w/Screws	09240 8	8	6
9241	1 x 4" (25 x 100mm) Strips	09241 5	4	6
★ 9242	1-3/8" (35mm) Square Pads w/Screws	09242 2	4	6
▶ 9243	2 x 2 x 2-1/2" (50 x 50 x 64mm) Triangle Pads	09243 9	4	6
★ 9244	2-1/8" (55mm) Square Pads w/Screws	09244 6	4	6
9248	2-3/4" (70mm) Pads w/Screws	09248 4	4	6
9249	1-1/4" (32mm) Nail-On Pads	09249 1	4	6
9452	1" (25mm) Pads w/Screws	09452 5	8	6
9453	2" (50mm) Pads w/Screws	09453 2	4	6
9454	2-1/2" (64mm) Pads w/Screws	09454 9	4	6
9455	1-1/2" (38mm) Pads w/Screws	09455 6	4	6
9456	7/8" (22mm) Pads w/Screws	09456 3	8	6
★ 9457	5/8" x 3" (16 x 75mm) Strips	09457 0	4	6
9468	1-1/2" (38mm) Hex Based Appliance Glide Thread Stem	09468 6	4	4
9469	7/8" (22mm) Pads Nail-on	09469 3	8	6
★ 9471	Slide Glide Dinette Set 16 -1" (25mm) Pads w/Screws 4 -1-1/2" (38mm) Pads w/Screws	09471 6	20 16 4	6

★ Not Stocked in Canada – Call for Lead-time
▶ Available Only in Canada



Low Friction Mover Pads. Easy to use, then remove and store.

Slide Glide® Movers Pads

ITEM #	DESCRIPTION	U.P.C. (0 39003)	PCS/ PKG	PKG/ CTN
★ 9335	3 x 3" (75mm) Black Squares	09335 1	4	6
9336	3 x 3" (75mm) Almond Squares	09336 8	4	6
★ 9337	3 x 3" (75mm) White Squares	09337 5	4	6
9338	5-3/4" x 8" (150 x 200mm) Pads	09338 2	4	3

★ Not Stocked in Canada – Call for Lead-time



SLIDEGLIDE⁺

Slide objects easily

SLIDE GLIDE[®] PLUS

SLIDE GLIDE Plus[®] removes the friction between your furniture and carpeting which allows you to safely move heavy or cumbersome objects with ease and without damage. Assorted sizes and shapes available for every moving purpose.

Slide Glide Plus



ITEM #	DESCRIPTION	U.P.C. (0 39003)	PCS/ PKG	PKG/ CTN
▶ 3941	3/4" (19mm) Round Self-Adhesive	03941 0	4	6
▶ 3942	1" (25mm) Round Self-Adhesive	03942 7	4	6
▶ 3943	1-1/2" (38mm) Round Self-Adhesive	03943 4	4	6
▶ 3944	2" (50mm) Round Self-Adhesive	03944 1	4	6
▶ 3945	2-1/2" (64mm) Round Self-Adhesive	03945 8	4	6
▶ 3946	2 x 2 x 2-1/2" (50 x 50 x 64mm) Triangle Pads	0 3946 5	4	6
▶ 3947	3-1/2" x 3-1/2" x 4-1/2" Triangle Self-Adhesive	03947 2	4	4
▶ 3948	1" (25mm) Square Self-Adhesive	03948 9	4	6
▶ 3949	2" (50mm) Square Self-Adhesive	03949 6	4	6
▶ 3950	1/2" x 4" (13 x 100mm) Strip Self-Adhesive	03950 2	4	6
3951	Value Pack 16 x 1" & 4 x 1-3/4" Round Self-Adhesive	03951 9	20	6
▶ 3953	1" (25mm) Round Hollow Nail	03953 3	8	6
3955	3-1/2" Round / not Self-Adhesive / Store & Reuse	03955 7	4	4
▶ 3956	5" (125mm) Square / not Self-Adhesive / Store & Reuse	03956 4	4	4
3957	Value Pack set of 4 each 7" & 3-1/2" Round / Store & Reuse	03957 1	8	4
▶ 3958	2-1/2" x 9" Rectangle / not Self-Adhesive / Store & Reuse	03958 8	4	4
9314	5" (125mm) Furniture Slide w/Fleece Socks	09314 6	8	4
9316	4" (100mm) Furniture Slide / Store & Reuse	09316 0	4	4

▶ Available Only in Canada

NEW Packaging
Available On All Slide Glide[®] Products



GLIDES

Carpet Base Nail-On Glide. For installation in wooden legs. Not for use on chair legs.
Cushioned Nail-On Glide. For installation in wooden legs. Helps furniture move smoothly over flooring. Nickel and plastic base.
Nail-On Swivel Glide. For angled wooden legs. Protects both furniture and flooring surface.
Nail-On Glide-Plastic Base. For installation in wooden legs. Not for use on chair legs.
Swivel Glide. Glides fit over tubular metal legs such as dinette sets. Allows furniture to move smoothly over floors. Brass plated with swivel plastic base.
Threaded Stem Glide. Helps level office and household furniture with threaded sockets.



Carpet Base Nail-On Glides

ITEM #	DESCRIPTION	U.P.C. (0 39003)	PCS/ PKG	PKG/ CTN
9103	1" (25mm) Carpet Base Nail-On Glides	09103 6	4	6
9155	1-1/4" (32mm) Carpet Base Nail-On Glides	09155 5	4	6

Cushioned Nail-On Glides

9099	7/8" (22mm) Nickel Cushioned Nail-On Glides	09099 2	4	6
9100	1-1/16" (27mm) Nickel Cushioned Nail-On Glides	09100 5	4	6
9101	1-1/4" (32mm) Nickel Cushioned Nail-On Glides	09101 2	4	6
9445	5/8" (16mm) Plastic Cushioned Nail-On Glides	09445 7	4	6
9446	3/4" (19mm) Plastic Cushioned Nail-On Glides	09446 4	4	6
9447	7/8" (22mm) Plastic Cushioned Nail-On Glides	09447 1	4	6
9448	1-1/8" (29mm) Plastic Cushioned Nail-On Glides	09448 8	4	6
9513	1-1/2" (38mm) Plastic Cushioned Nail-On Glides	09513 3	4	6

Nail-On Swivel Glides

9098	1" (25mm) Nylon - Brass Plated Nail-On Swivel Glide	09098 5	4	6
------	---	---------	---	---

Plastic Base Tack Glides

9102	7/8" (22mm) Plastic Base Tack Glides	09102 9	4	6
9143	5/8" (16mm) Plastic Base Tack Glides	09143 2	4	6
9144	3/4" (19mm) Plastic Base Tack Glides	09144 9	4	6

Swivel Glides

▶ 9094	5/8" (16mm) I.D. Nylon - Brass Plated Swivel Glides	09094 7	4	6
▶ 9095	3/4" (19mm) I.D. Nylon - Brass Plated Swivel Glides	09095 4	4	6
▶ 9096	7/8" (22mm) I.D. Nylon - Brass Plated Swivel Glides	09096 1	4	6
▶ 9097	1" (25mm) I.D. Nylon - Brass Plated Swivel Glides	09097 8	4	6

▶ Available Only in Canada

Threaded Stem Glides

9444	1-1/4" (32mm) Threaded Stem Glide Phenolic Base 5/16" x 18 Thread 1-1/2" (8mm x 18 x 38mm) Long	09444 0	4	6
9449	7/8" (22mm) Threaded Stem Glide Metal Base w/Rubber Cushion 1/4" x 20 Thread 1/2" (6mm x 20 x 13mm) Long	09449 5	4	6
9450	1-1/16" (27mm) Threaded Stem Glide Metal Base w/Rubber Cushion 1/4" x 20 Thread 1/2" (6mm x 20 x 13mm) Long	09450 1	4	6
9451	1-1/4" (32mm) Threaded Stem Glide Metal Base w/Rubber Cushion 1/4" x 20 Thread 1/2" (6mm x 20 x 13mm) Long	09451 8	4	6

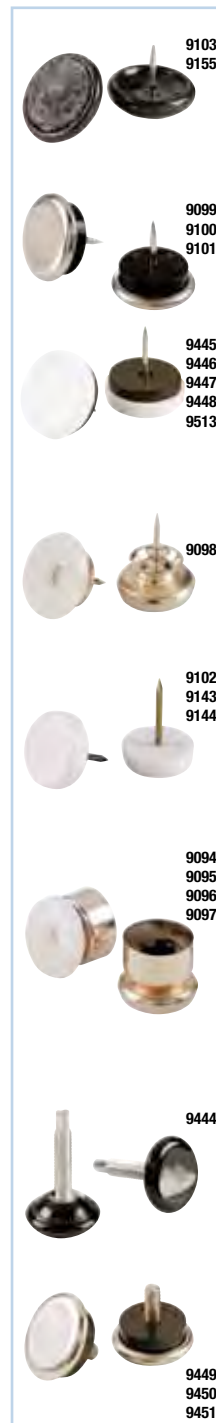

GLIDES (cont'd)



WonderLevel®. Table leveler that automatically adjusts to uneven floors. Use with either our FeltGard® pads for wood and other hard surface floors or Slide Glide® pads for carpeted floors.



ITEM #	DESCRIPTION	Load Capacity	U.P.C. (0 39003)	PCS/ PKG	PKG/ CTN
9485	WonderLevel Self Leveling Table Glides Pack	35lbs(16kg)	09485 3	17	6
	4 - 1" (25mm) Levelers with 1/4" (6mm) 20 Threaded Stem			4	
	4 - 1" (25mm) Slide Glide® Pads			4	
	4 - 1" (25mm) FeltGard® Pads			4	
	4 - 1/2" (13mm) Plastic Sockets for Wood Legs			4	
	1 - Hex Wrench			1	



SLIDER n GRIPPER

Slider n Gripper pads, glides and cups fall into three distinct categories, Slider, Gripper, and dual function - Slider and Gripper. Slider protects floor surfaces and is perfect for small furniture such as chairs. Gripper offers optimum grip and is used when you prefer furniture to resist movement. Dual function pads and risers grip when flat but slide easily without damaging your floor when tilted.

»» Furniture Pads, Glides and Cups

ITEM #	DESCRIPTION		U.P.C. (0 39003)	PCS/ PKG	PKG/ CTN
3687	3-1/4" (82mm) Wood Effect Dual Function Furniture Pad	<i>Slide & Grip</i>	03687 7	4	4
3691	1" (25mm) Wood Effect Furniture Glide	<i>Slide only</i>	03691 4	8	6
3692	1-1/4" (32mm) Non Slip Wood Effect Furniture Pad	<i>Grip only</i>	03692 1	8	6
3693	2" (50mm) Wood Effect Non Slip Furniture Cup	<i>Slide & Grip</i>	03693 8	4	6
★ 3694	3/4" (19mm) Wood Effect Furniture Glide	<i>Slide only</i>	03694 5	16	6
3696	Large Caster Wood Effect 2-1/4" I.D. (56mm) Non Slip Furn. Cup	<i>Grip only</i>	03696 9	4	4
3697	Small Caster Wood Effect 1-3/4" I.D. (44mm) Non Slip Furn. Cup	<i>Grip only</i>	03697 6	4	6

★ Not Stocked in Canada – Call for Lead-time

»» Slider n Gripper Wire Rack Display



ITEM #	DESCRIPTION		U.P.C. (0 39003)	FAC- ING	QTY/ PNL
★ 3705	Display includes Wire Rack, 6 Hooks, Header Sign & Product Assortment		—	—	—
	Contents include:				
3687	3-1/4" (82mm) Wood Effect Dual Function Furniture Pad		03687 7	1	4
3691	1" (25mm) Wood Effect Furniture Glide		03691 4	1	6
3692	1-1/4" (32mm) Non Slip Wood Effect Furniture Pad		03692 1	1	6
3693	2" (50mm) Wood Effect Non Slip Furniture Cup		03693 8	1	6
3694	3/4" (19mm) Wood Effect Furniture Glide		03694 5	1	6
3696	Large Caster Wood Effect 2-1/4" I.D. (56mm) Non Slip Furniture Cup		03696 9	1	4

★ Not Stocked in Canada – Call for Lead-time

LIGHT & MEDIUM DUTY FELT



Scratch resistant **SURFACE GARD®** pads are easy to install protection for cabinets, counter tops, end tables, etc. against damage from accidental marring.

Light Duty Self-Adhesive Felt Pads

ITEM #	DESCRIPTION	U.P.C. (0 39003)	PCS/ PKG	PKG/ CTN
9421	3/8" (10mm) Pads - Green	09421 1	28	12
9423	Assorted Green Felt Pads	09423 5	46	12
★ 9425	Assorted Brown Felt Pads	09425 9	46	12
9433	6" x 18" (15 x 46cm) Green Felt Blanket	09433 4	1	12

★ Not Stocked in Canada – Call for Lead-time



Medium Duty Self-Adhesive Felt Pads

ITEM #	DESCRIPTION	U.P.C. (0 39003)	PCS/ PKG	PKG/ CTN
9021	3/8" (10mm) Pads - Beige	09021 3	75	12
9427	4-1/4" x 6" (108 x 150mm) Sheets - Green	09427 3	2	12
▶ 9820	1/2" (13mm) Round Green Medium Duty Felt	09820 2	24	12
★ 9821	3/4" (19mm) Round Green Medium Duty Felt	09821 9	12	12
9822	1" (25mm) Round Brown Medium Duty Felt	09822 6	4	12
★ 9823	1" (25mm) Square Brown Medium Duty Felt	09823 3	4	12
▶ 9941	Value Pack 1- 4-1/4" x 6" (108 x 150mm) Brown Sheet 12 - 3/4" (19mm) - Brown Pads 12 - 3/4" (19mm) - Brown Square Pads 24 - 1/2" (13mm) - Brown Pads 50 - 3/8" (10mm) - White Pad	09941 4	99	36
9949	3/8" (10mm) Pads - Brown	09949 0	75	12
9956	4-1/4" x 6" (108 x 150mm) Sheets - Brown	09956 8	2	12
9957	3/8" (10mm) Pads - White	09957 5	75	12
9958	1/2" (13mm) Pads - Brown	09958 2	24	12
9959	3/4" (19mm) Pads - Brown	09959 9	12	12
9960	3/4" (19mm) Pads - Brown Square	09960 5	12	12



★ Not Stocked in Canada – Call for Lead-time
▶ Available Only in Canada



CORK, NON-SKID FOAM, VINYL PADS & BUMPERS



»»» Cork, Non-Skid Foam & Vinyl Self-Adhesive Pads

ITEM #	DESCRIPTION	U.P.C. (0 39003)	PCS/ PKG	PKG/ CTN
★ 9560	1/2" (13mm) White Vinyl Pads - Square	09560 7	9	6
★ 9561	1/2" (13mm) Brown Vinyl Pads - Square	09561 4	9	6
9562	1/2" (13mm) Clear Vinyl Pads - Square	09562 1	9	6
★ 9563	3/4" (19mm) White Vinyl Pads - Square	09563 8	12	6
★ 9564	3/4" (19mm) Brown Vinyl Pads - Square	09564 5	12	6
9565	3/4" (19mm) Clear Vinyl Pads - Square	09565 2	12	6
9961	3/4" (19mm) Cork Pads - Round	09961 2	12	12
9962	1/2" (13mm) Cork Pads - Round	09962 9	24	6
9964	3/8" (10mm) Clear Vinyl Pads - Round	09964 3	16	12
9965	3/4" (19mm) Clear Vinyl Pads - Round	09965 0	8	12
9966	3/4" (19mm) Clear Vinyl Non-Adhesive Discs - Round	09966 7	10	12
9967	1/2" (13mm) Clear Vinyl Pads - Round	09967 4	16	12
▶ 9969	Value Pack - 3/8" (10mm) Clear Vinyl Pads - 1/2" (13mm) Clear Vinyl Pads - 3/4" (19mm) Clear Vinyl Pads	09969 8	36	12
9973	3/4" (19mm) Foam Non-Skid Pads	09973 5	12	6
9974	1/2" (13mm) Foam Non-Skid Pads	09974 2	24	6
9980	1/2" x 2-3/8" (13 x 60mm) Foam Non-Skid Strips	09980 3	6	12
★ 9943	Value Pack 24 - 1/2" (13mm) Cork Pads 12 - 3/4" (19mm) Cork Pads 24 - 1/2" (13mm) Foam Non-Skid Pads 12 - 3/4" (19mm) Foam Non-Skid Pads 16 - 3/8" (10mm) Clear Vinyl Pads	09943 8	88	36
▶ 9943D	Value Pack 24 - 1/2" (13mm) Cork Pads 12 - 3/4" (19mm) Cork Pads 24 - 1/2" (13mm) Foam Non-Skid Pads 12 - 3/4" (19mm) Foam Non-Skid Pads 16 - 3/8" (10mm) Clear Vinyl Pads	09943 8	88	12

★ Not Stocked in Canada – Call for Lead-time
▶ Available Only in Canada



SCREW & TACK BUMPERS

Screw and Tack Bumpers protect surfaces from being damaged while also deadening sound.

»»» Rubber & Plastic Bumpers

ITEM #	DESCRIPTION	U.P.C. (0 39003)	PCS/ PKG	PKG/ CTN
9131	7/8" (22mm) Screw Off-White Rubber	09131 9	4	6
★ 9135	5/8" (16mm) Tack Black Plastic	09135 7	4	6
★ 9151	3/4" (19mm) Screw Grey Soft Plastic	09151 7	4	6

★ Not Stocked in Canada – Call for Lead-time

CUPS

Carpet Base. Round or square cups used to protect hard floors from scratches and dents.

Plastic Spiked. Round or square cups used to prevent crushing and excess wear of carpet pile.

Plastic. Round or square cups used to prevent crushing and wearing of carpet pile as well as protecting hard floors from scratches and dents.

Rubber. Round or square cups used to protect hard floors from scratches and dents.

Woodgrain Effect. Round cups that imitate wood grain appearance while protecting hard floors from scratches and dents.

Carpet Base Cups

ITEM #	DESCRIPTION	U.P.C. (0 39003)	PCS/ PKG	PKG/ CTN
9080	1-7/8" (48mm) Square	09080 0	4	6
9090	1-1/4" (32mm) Round	09090 9	4	6
9091	2" (50mm) Round	09091 6	4	6
9092	2-1/2" (64mm) Round	09092 3	4	6
9079	3" (75mm) Round	09079 4	4	6

Clear Smooth Plastic Cups

ITEM #	DESCRIPTION	U.P.C. (0 39003)	PCS/ PKG	PKG/ CTN
9087	1-7/16" (36mm) Round	09087 9	4	6
9088	1-7/8" (48mm) Round	09088 6	4	6
★ 9089	1-7/8" (48mm) Square	09089 3	4	6

★ Not Stocked in Canada – Call for Lead-time

Clear Plastic Spiked Cups

ITEM #	DESCRIPTION	U.P.C. (0 39003)	PCS/ PKG	PKG/ CTN
▶ 9056	2-1/8" (54mm) I.D. for Standard Bed Frame Caster Round	09056 5	4	6
9081	1-1/2" (38mm) Round	09081 7	4	6
9082	1-7/8" (48mm) Round	09082 4	4	6
9083	1-7/8" (48mm) Square	09083 1	4	6

LITTLE KNOWN BENEFIT:
After cleaning your carpets, using spiked plastic cups allows furniture to be placed immediately without either rust or wood stains marks forming.

Smooth Rubber Cups

ITEM #	DESCRIPTION	U.P.C. (0 39003)	PCS/ PKG	PKG/ CTN
★ 9164	1-5/8" (40mm) Square Off-White	09164 7	4	6
★ 9165	1-1/2" (38mm) Round Off-White	09165 4	4	6
9166	2" (50mm) Square Off-White	09166 1	4	6
9167	1-3/4" (44mm) Round Off-White	09167 8	4	6
9168	3" (75mm) Square Off-White	09168 5	2	6
9074	1-5/8" (40mm) Square Brown	09074 9	4	6
9075	1-1/2" (38mm) Round Brown	09075 6	4	6
9076	2" (50mm) Square Brown	09076 3	4	6
9077	1-3/4" (44mm) Round Brown	09077 0	4	6
9078	3" (75mm) Square Brown	09078 7	2	6

★ Not Stocked in Canada – Call for Lead-time

Woodgrain Effect Cups

ITEM #	DESCRIPTION <i>All dimensions are I.D.</i>	U.P.C. (0 39003)	PCS/ PKG	PKG/ CTN
9058	2-3/8" (60mm) Light Woodgrain Effect w/Non-Slip TPR Base	09058 9	4	6
▶ 9059	1-3/4" (44mm) Dark Woodgrain Effect w/Non-Slip TPR Base	09059 6	4	6
▶ 9060	2-3/8" (60mm) Dark Woodgrain Effect w/Non-Slip TPR Base	09060 2	4	6
▶ 9361	1-3/4" (44mm) Dark Woodgrain Effect w/Felt Base	09361 0	4	6
▶ 9362	2-3/8" (60mm) Dark Woodgrain Effect w/Felt Base	09362 7	4	6
9363	1-3/4" (44mm) Light Woodgrain Effect w/Felt Base	09363 4	4	6
9364	2-3/8" (60mm) Light Woodgrain Effect w/Felt Base	09364 1	4	4

▶ Available Only in Canada

www.shepherdhardware.com



DOOR STOPS



Cushion. Soft vinyl door stops protects wall opposite door knobs. Self-adhesive back. Available in ivory, white and clear.

Foot Operated. Fits securely beneath standard internal doors and can be used on both hard or soft floor coverings. Effortlessly releases when you step on door stop.

Spring. Screw mounted door stops helps to protect walls.

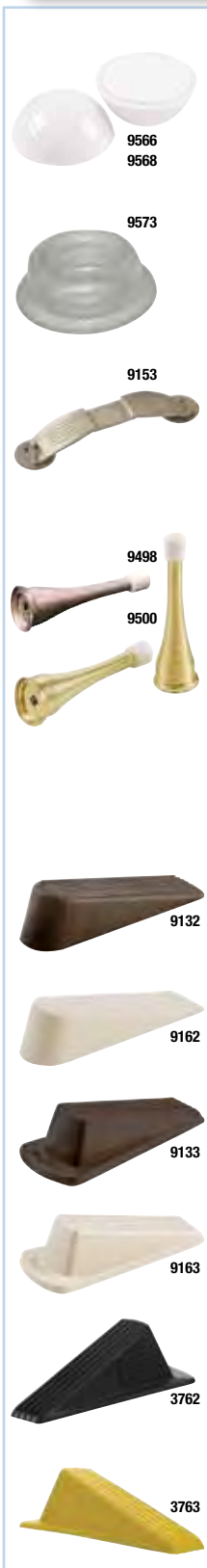

»»» Cushion Door Stop

ITEM #	DESCRIPTION	U.P.C. (0 39003)	PCS/ PKG	PKG/ CTN
★ 9566	Ivory	09566 9	2	6
9568	White	09568 3	2	6
★ 9573	Clear	09573 7	1	6

★ Not Stocked in Canada – Call for Lead-time

»»» Foot Operated Door Stop

ITEM #	DESCRIPTION	U.P.C. (0 39003)	PCS/ PKG	PKG/ CTN
▶ 9153	9-1/2" (24cm) Foot Operated Door Stop	09153 1	1	6

▶ Available Only in Canada

»»» Spring Door Stop

ITEM #	DESCRIPTION	U.P.C. (0 39003)	PCS/ PKG	PKG/ CTN
9498	Nickel	09498 3	2	6
▶ 9500	Brass	09500 3	2	6

▶ Available Only in Canada



Wedges. Rubber wedge to secure doors.

Jumbo Door Wedge. Designed to secure extra large or heavy doors. Large footprint grips on rough or uneven surfaces and large heel holds doors with clearances up to 2" (50mm) from floor surface.

»»» Rubber Wedges

ITEM #	DESCRIPTION	U.P.C. (0 39003)	PCS/ PKG	PKG/ CTN
9132	Brown	09132 6	2	6
9162	Off-White	09162 3	2	6
9133	Heavy Duty Brown	09133 3	1	6
9163	Heavy Duty Off-White	09163 0	1	6
▶ 3762	Jumbo Heavy Duty Black	03762 1	1	4
3763	Jumbo Heavy Duty Yellow	03763 8	1	4

▶ Available Only in Canada

LEG TIPS

Hi-Vinyl. Easy gliding on carpet and hard flooring. Use on tubular metal or wood furniture. Available in white or black.

Plastic. Easy gliding on carpet and hard flooring. Use on tubular metal or wood furniture. Available in white or black.

Crutch Tips. For use on crutches, canes, and walkers. More durability and better suction than regular rubber tips. Reinforced steel disc on the inside.

Rubber. Non-skid rubber tips. Available in white or black.

Hi-Vinyl

ITEM #	DESCRIPTION	U.P.C. (0 39003)	PCS/ PKG	PKG/ CTN
★ 9205	1/2" (13mm) White	09205 7	4	6
★ 9200	5/8" (16mm) White	09200 2	4	6
9201	3/4" (19mm) White	09201 9	4	6
9202	7/8" (22mm) White	09202 6	4	6
9203	1" (25mm) White	09203 3	4	6
★ 9204	1-1/8" (29mm) White	09204 0	4	6
▶ 9215	1/2" (13mm) Black	09215 6	4	6
▶ 9210	5/8" (16mm) Black	09210 1	4	6
▶ 9211	3/4" (19mm) Black	09211 8	4	6
▶ 9212	7/8" (22mm) Black	09212 5	4	6
▶ 9213	1" (25mm) Black	09213 2	4	6
▶ 9214	1-1/8" (29mm) Black	09214 9	4	6

★ Not Stocked in Canada – Call for Lead-time
▶ Available Only in Canada



9205
9200
9201
9202
9203
9204

9215
9210
9211
9212
9213
9214

Plastic

ITEM #	DESCRIPTION	U.P.C. (0 39003)	PCS/ PKG	PKG/ CTN
★ 9105	1/2" (13mm) White	09105 0	4	6
9106	5/8" (16mm) White	09106 7	4	6
9107	3/4" (19mm) White	09107 4	4	6
9108	7/8" (22mm) White	09108 1	4	6
9109	1" (25mm) White	09109 8	4	6
9744	1-1/8" (29mm) White	09744 1	4	6
9745	1-1/4" (32mm) White	09745 8	4	6
9111	1/2" (13mm) Black	09111 1	4	6
9112	5/8" (16mm) Black	09112 8	4	6
9113	3/4" (19mm) Black	09113 5	4	6
9114	7/8" (22mm) Black	09114 2	4	6
9115	1" (25mm) Black	09115 9	4	6
9768	1-1/8" (29mm) Black	09768 7	4	6
9769	1-1/4" (32mm) Black	09769 4	4	6

★ Not Stocked in Canada – Call for Lead-time



9104
9105
9106
9107
9108
9109
9744
9745

9110
9111
9112
9113
9114
9115
9160
9768
9769

Crutch Tips

ITEM #	DESCRIPTION	U.P.C. (0 39003)	PCS/ PKG	PKG/ CTN
★ 9742	3/4" - 7/8" (19-22mm) Off-White	09742 7	2	6

★ Not Stocked in Canada – Call for Lead-time



9742

LEG TIPS (cont'd)

►► Rubber



ITEM #	DESCRIPTION	U.P.C. (0 39003)	PCS/ PKG	PKG/ CTN
★ 9117	1/2" (13mm) Off-White	09117 3	4	6
9118	5/8" (16mm) Off-White	09118 0	4	6
9119	3/4" (19mm) Off-White	09119 7	4	6
9120	7/8" (22mm) Off-White	09120 3	4	6
9121	1" (25mm) Off-White	09121 0	4	6
9122	1-1/8" (29mm) Off-White	09122 7	4	6
9223	1-1/4" (32mm) Off-White	09223 1	2	6
★ 9225	1-1/2" (38mm) Off-White	09225 5	2	6
► 9123	3/8" (10mm) Black	09123 4	4	6
9124	1/2" (13mm) Black	09124 1	4	6
9125	5/8" (16mm) Black	09125 8	4	6
9126	3/4" (19mm) Black	09126 5	4	6
9127	7/8" (22mm) Black	09127 2	4	6
9128	1" (25mm) Black	09128 9	4	6
9129	1-1/8" (29mm) Black	09129 6	4	6
9224	1-1/4" (32mm) Black	09224 8	2	6
★ 9226	1-1/2" (38mm) Black	09226 2	2	6

★ Not Stocked in Canada – Call for Lead-time
 ► Available Only in Canada

►► Bulk Rubber

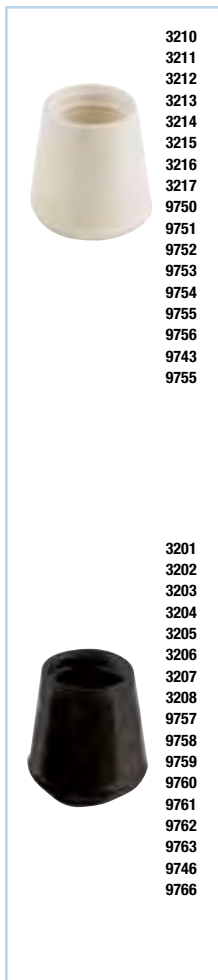

ITEM #	DESCRIPTION	U.P.C. (0 39003)	PCS/ PKG	PKG/ CTN
★ 3201	1/2" (13mm) Bulk Individual Poly Bag Black	03201 5	1	40
★ 3202	5/8" (16mm) Bulk Individual Poly Bag Black	03202 2	1	40
★ 3203	3/4" (19mm) Bulk Individual Poly Bag Black	03203 9	1	40
★ 3204	7/8" (22mm) Bulk Individual Poly Bag Black	03204 6	1	40
★ 3205	1" (25mm) Bulk Individual Poly Bag Black	03205 3	1	40
★ 3206	1-1/8" (29mm) Bulk Individual Poly Bag Black	03206 0	1	40
★ 3207	1-1/4" (32mm) Bulk Individual Poly Bag Black	03207 7	1	40
★ 3208	1-1/2" (38mm) Bulk Individual Poly Bag Black	03208 4	1	40
★ 3210	1/2" (13mm) Bulk Individual Poly Bag Off-White	03210 7	1	40
★ 3211	5/8" (16mm) Bulk Individual Poly Bag Off-White	03211 4	1	40
★ 3212	3/4" (19mm) Bulk Individual Poly Bag Off-White	03212 7	1	40
★ 3213	7/8" (22mm) Bulk Individual Poly Bag Off-White	03213 8	1	40
★ 3214	1" (25mm) Bulk Individual Poly Bag Off-White	03214 5	1	40
★ 3215	1-1/8" (29mm) Bulk Individual Poly Bag Off-White	03215 2	1	40
★ 3216	1-1/4" (32mm) Bulk Individual Poly Bag Off-White	03216 9	1	40
★ 3217	1-1/2" (38mm) Bulk Individual Poly Bag Off-White	03217 6	1	40
★ 9751	1/2" (13mm) Off-White	09751 9	1	24
★ 9752	5/8" (16mm) Off-White	09752 6	1	24
★ 9753	3/4" (19mm) Off-White	09753 3	1	24
★ 9754	7/8" (22mm) Off-White	09754 0	1	24
★ 9755	1" (25mm) Off-White	09755 7	1	24
★ 9756	1-1/8" (29mm) Off-White	09756 4	1	24
★ 9743	1-1/4" (32mm) Off-White	09743 4	1	24
★ 9765	1-1/2" (38mm) Off-White	09765 6	1	12
★ 9758	1/2" (13mm) Black	09758 8	1	24
★ 9759	5/8" (16mm) Black	09759 5	1	24
★ 9760	3/4" (19mm) Black	09760 1	1	24
★ 9761	7/8" (22mm) Black	09761 8	1	24
★ 9762	1" (25mm) Black	09762 5	1	24
★ 9763	1-1/8" (29mm) Black	09763 2	1	24
★ 9746	1-1/4" (32mm) Black	09746 5	1	24
★ 9766	1-1/2" (38mm) Black	09766 3	1	12

★ Not Stocked in Canada – Call for Lead-time

LEG TIPS (cont'd)

Tips with Felt. Long wearing heavy duty felt adhered to durable plastic leg tips. For use on tubular metal or wood furniture legs on hard floor surfaces. Available in two colors and four sizes.

Tips. Available in round, square, angled or straight. For use on tubular metal or wood furniture legs on carpeted and hard floor surfaces.

Inside Tips. Same as tips except fit inside tubular metal furniture legs.

Plastic Leg Tips with Felt

ITEM #	DESCRIPTION	U.P.C. (0 39003)	PCS/ PKG	PKG/ CTN
3921	LEG TIP: w/Felt Plastic White, 3/4" (19mm) Round	03921 2	4	6
3922	LEG TIP: w/Felt Plastic White, 7/8" (22mm) Round	03922 9	4	6
3923	LEG TIP: w/Felt Plastic White, 1" (25mm) Round	03923 6	4	6
3924	LEG TIP: w/Felt Plastic White, 1-1/4" (32mm) Round	03924 3	4	6
3931	LEG TIP: w/Felt Plastic Black, 3/4" (19mm) Round	03931 1	4	6
3932	LEG TIP: w/Felt Plastic Black, 7/8" (22mm) Round	03932 8	4	6
3933	LEG TIP: w/Felt Plastic Black, 1" (25mm) Round	03933 5	4	6
3934	LEG TIP: w/Felt Plastic Black, 1-1/4" (32mm) Round	03934 2	4	6



Plastic Square Tips

ITEM #	DESCRIPTION	U.P.C. (0 39003)	PCS/ PKG	PKG/ CTN
9234	1" (25mm)	09234 7	4	6



Plastic Angle Inside Tips

ITEM #	DESCRIPTION	U.P.C. (0 39003)	PCS/ PKG	PKG/ CTN
▶ 9238	3/4" (19mm)	09238 5	4	6
▶ 9239	7/8" (22mm)	09239 2	4	6

▶ Available Only in Canada



Plastic Inside Tips

ITEM #	DESCRIPTION	U.P.C. (0 39003)	PCS/ PKG	PKG/ CTN
▶ 9206	3/4" (19mm) Round - fits 3/4" O.D. Chair leg	09206 4	4	6
▶ 9207	7/8" (22mm) Round - fits 7/8" O.D. Chair leg	09207 1	4	6
▶ 9208	1" (25mm) Round - fits 1" O.D. Chair leg	09208 8	4	6
▶ 9209	1-1/4" (32mm) Round - fits 1-1/4" O.D. Chair leg	09209 5	4	6
9235	3/4" (19mm) Square	09235 4	4	6
9236	7/8" (22mm) Square	09236 1	4	6
9237	1" (25mm) Square	09237 8	4	6

▶ Available Only in Canada

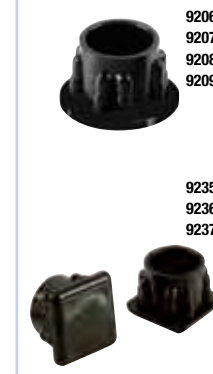

REPLACEMENT TIPS



Inserts. Fits into tubular casual furniture protecting both the furniture and the floor.

Inserts - Dome. Domed tip has a universal insert tip that fits into tubular furniture. Tip is effective on both straight and angled legs.

Tips. Easy gliding, heavy gauge plastic tip.

Inserts - Square. Tips fit into tubular casual furniture to protect both furniture and flooring.

Insert Cups. Chair base cup inserts into the foot of wrought iron furniture legs protecting both the furniture and flooring surface.

Umbrella Hole Ring. Umbrella hole caps plug the umbrella hole in casual furniture providing a flat smooth table surface.

Round Plastic Inserts

ITEM #	DESCRIPTION	U.P.C. (0 39003)	PCS/ PKG	PKG/ CTN
★ 3010	3/4" (19mm) I.D. 7/8" (22mm) O.D. White	03010 3	4	6
★ 3011	7/8" (22mm) I.D. 1" (25mm) O.D. White	03011 0	4	6

★ Not Stocked in Canada – Call for Lead-time

Round Dome Plastic Inserts

ITEM #	DESCRIPTION	U.P.C. (0 39003)	PCS/ PKG	PKG/ CTN
★ 3015	1" (25mm) White	03015 8	4	6

★ Not Stocked in Canada – Call for Lead-time

Heavy Plastic Round Patio Tips

ITEM #	DESCRIPTION	U.P.C. (0 39003)	PCS/ PKG	PKG/ CTN
▶ 3005	1-1/4" (32mm) White	03005 9	4	6

▶ Available Only in Canada

Square Plastic Inserts

ITEM #	DESCRIPTION	U.P.C. (0 39003)	PCS/ PKG	PKG/ CTN
★ 3020	13/16" (21mm) White	03020 2	4	6

★ Not Stocked in Canada – Call for Lead-time

Square Vinyl Inserts

ITEM #	DESCRIPTION	U.P.C. (0 39003)	PCS/ PKG	PKG/ CTN
★ 3025	5/8" (16mm) Clear w/Round Bottom	03025 7	4	6

★ Not Stocked in Canada – Call for Lead-time

Round Insert Cups

ITEM #	DESCRIPTION	U.P.C. (0 39003)	PCS/ PKG	PKG/ CTN
★ 3039S	CLIP STRIP 1-1/4" (32mm) White	03039 4	4	6
3040	1-1/2" (38mm) White	03040 0	4	6
★ 3040S	CLIP STRIP 1-1/2" (38mm) White	03040 0	4	6

★ Not Stocked in Canada – Call for Lead-time

Umbrella Hole Ring Set

ITEM #	DESCRIPTION	U.P.C. (0 39003)	PCS/ PKG	PKG/ CTN
★ 3030	2" (50mm) Clear Plastic	03030 1	1	6

★ Not Stocked in Canada – Call for Lead-time



MISCELLANEOUS

Bed Risers. Adds five inches to the height of the space under your bed to accommodate bulkier items or storage boxes.

Continental Bed Legs. Sturdy wood replacement legs for beds and other home or office furnishings, such as sofas, daybeds, loveseats, club chairs, ottomans, etc.

Fleece Blankets and Rolls. Soft, absorbent fleece blanket has an anti-skid, moisture impermeable plastic backing bonded to the underside.

Lazy Susan Turntables. Ball bearing turntable for rotating book racks, business machine stands, serving trays, kitchen storage racks, etc.

Movers Blanket. Provides additional padded protection for business equipment or furniture during moves or storage.

Bed Risers

- Adds five inches of useable space to accommodate taller storage boxes
- Fits casters or bed posts up to 3" diameter
- Use indoors or out - Countless uses
- Impervious to insect and water damage
- Load capacity per riser 300 lbs.

Multi-purpose risers are ideal for your home, garage, office or outdoor use.



ITEM #	DESCRIPTION	LOAD CAP LB (KG)	U.P.C. (0 39003)	PCS/ PKG	PKG/ CTN
★ 9523	6-1/8" (155mm) Molded Bed Riser Black	300lb (136kg)	09523 2	4	6

★ Not Stocked in Canada – Call for Lead-time

Continental Bed Legs

ITEM #	DESCRIPTION	U.P.C. (0 39003)	PCS/ PKG	PKG/ CTN
▶ 9522	6" (150mm) Continental Bed Legs	09522 5	6	4



▶ Available Only in Canada

Fleece Blanket & Rolls

- Slip-resistant undersurface for secure grip
- Moisture can't wick up or seep down
- Use indoors or out - Reuseable
- Compact size allows for easy storage anywhere



ITEM #	DESCRIPTION	U.P.C. (0 39003)	PCS/ PKG	PKG/ CTN
9853	Fleece Blanket 3' x 5' (1M x 1.5M)	09859 2	1	5
9859	Fleece Roll 3' x 16' (1M x 5M)	09859 2	1	5
9859D	DISPLAY MERCHANDISER: POP Fleece Display contains 20 fleece rolls	09859 2	1	20

Lazy Susan Turntables

ITEM #	DESCRIPTION	LOAD CAP LB (KG)	U.P.C. (0 39003)	PCS/ PKG	PKG/ CTN
9546	3" (75mm) Square	200lb (91kg)	09546 1	1	10
9547	4" (100mm) Square	300lb (136kg)	09547 8	1	10
9548	6" (150mm) Square	400lb (181kg)	09548 5	1	5
9549	12" (300mm) Round	500lb (228kg)	09549 2	1	5

Movers Blanket

ITEM #	DESCRIPTION	U.P.C. (0 39003)	PCS/ PKG	PKG/ CTN
★ 9851	72" x 80" (183 x 203cm), Box Packaged	09851 6	1	6
89851	Blankets 72" x 80" (183 x 203cm), Polybag Packaged	89851 2	1	5

★ Not Stocked in Canada – Call for Lead-time



PLASTIC SHIMS, VINYL COATED HOOKS, WALL PROTECTORS

Plastic Shims. Impervious to water and insect damage, use with construction, plumbing, wood cabinets, furniture, or for bracing items that tilt, move or are loose.

Vinyl Hooks. Use in garages or basements to organize large items such as tools, bicycles, and ladders.

Wall Protectors. Use to protect surfaces from door knob damage or cover existing damage. Self Adhesive and paintable circular disk available in two sizes, 3-1/4" and 5".

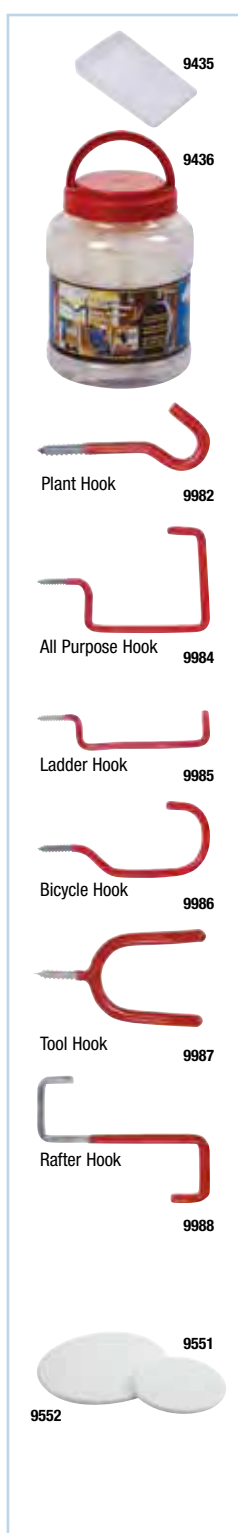

Plastic Shims



ITEM #	DESCRIPTION	U.P.C. (0 39003)	PCS/ PKG	PKG/ CTN
9435	Carded Shims	09435 8	6	6
★ 9436	Display Jar	09436 5	300	1

★ Not Stocked in Canada – Call for Lead-time

Vinyl Coated Storage Hooks

ITEM #	DESCRIPTION	U.P.C. (0 39003)	PCS/ PKG	PKG/ CTN
▶ 9982	Plant Hook	09982 7	2	12
▶ 9984	All Purpose Hook	09984 1	2	12
▶ 9985	Ladder Hook	09985 8	2	12
▶ 9986	Bicycle Hook	09986 5	2	12
▶ 9987	Tool Hook	09987 2	2	12
▶ 9988	Rafter Hook	09988 9	2	12

▶ Available Only in Canada

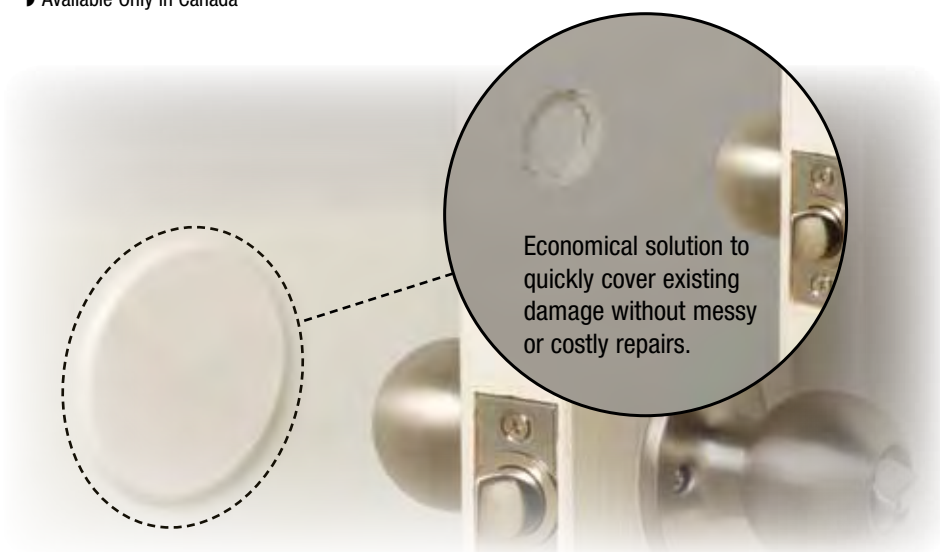

Wall & Door Knob Protector

ITEM #	DESCRIPTION	U.P.C. (0 39003)	PCS/ PKG	PKG/ CTN
★ 9551	3-1/4" (83mm) Wall & Door Knob Protector	09551 5	1	6
★ 9551S	Clip Strip: 3-1/4" (83mm) Wall & Door Knob Protector	09551 5	1	12
★ 9552	Clip Strip: 5" (125mm) Wall & Door Knob Protector	09552 2	1	6
★ 9552S	Clip Strip: 5" (125mm) Wall & Door Knob Protector	09552 2	1	12

★ Not Stocked in Canada – Call for Lead-time

SAFE KIDS

A line of Shepherd products to help protect a child from common household dangers.

ITEM #	DESCRIPTION	U.P.C. (0 39003)	PCS/ PKG	PKG/ CTN
▶ 3970	Safety Starter Pack: w/Re-useable Storage Box contains - 6 Drawer Safety Latches, 10 Socket Safety Plugs, 8 Corner Cushions, 1 Fridge/ Freezer Latch, 1 Safety Door Stop	3970 0	24	6
▶ 3971	Safety Latches: Easy to Use, Pull open door or drawer slightly, and press down on the hook to open. Latch will lock automatically when door or drawer closes.	3971 7	6	6
▶ 3972	Spring Latches: Easy to Use, Pull open door or drawer slightly, and press down on the hook to open. Latch will lock automatically when door or drawer closes.	3972 4	3	6
▶ 3973	Cupboard Slide Lock: Suitable for use with most mushroom shaped knobs and 'D' handles. Fits stem depths and diameters up to 3/4" (16mm) and up to 3-3/4" (96mm) apart.	3973 1	1	6
▶ 3974	Cupboard Slide Lock - Long: Suitable for use with most mushroom shaped knobs and 'D' handles. Extra long length secures handles and knobs up to 8-1/4" (210mm) apart.	3974 8	1	6
▶ 3975	Flexible Lock: Simple for adults to use - Difficult for children! Suitable for use with mushroom shaped knobs or 'D' handles. Extra long length straps secure handles & knobs up to 210mm (8-1/4") apart.	3975 5	1	6
▶ 3976	Flexi-Latches: Ideal for washing machine doors, toilet seats and all types of furniture cabinets. Easy to Use: - Gently pull off the strap from one disc, while pressing against surface. To Close - Press strap back onto the disc.	3976 2	2	6
▶ 3977	Flexi-Latches - Long: Ideal for washing machine doors, toilet seats and all types of furniture cabinets. Easy to Use: To Open - Gently pull off the strap from one disc, while pressing against surface. To Close - Press strap back onto the disc.	3977 9	1	6
▶ 3978	Angle Lock: Using Angle Lock: Push outward on the side release, while opening the drawer etc. Locks automatically when drawer closes.	3978 6	2	6
▶ 3979	Corner Cushions: Apply double-sided tape to all three inside surfaces of Corner Cushion and press firmly into the furniture corner.	3979 3	4	6
▶ 3980	Fridge & Freezer Latch: (May be suitable for other appliances)	3980 9	1	6
▶ 3981	Outlet Plugs: Insert plug into all unused electrical sockets.	3981 6	12	6
▶ 3982	Cord Wind-Ups: Long cords on blinds and window curtains are safely secured beyond children's reach	3982 3	2	6
▶ 3983	Safety Door Stop: Prevents doors from completely closing when in proximity of children. Intended for interior doors	3983 0	1	6
▶ 3984	Bath Thermometer: Avoid scalds and ensures baby's comfort	3984 7	1	6
▶ 3985	Bath Grip Appliques: Heat Sensing\Dual Function - textured surface prevents slips or falls\turn white when the water temperature is too hot.	3985 4	12	6
▶ 3986	Baby on Board Sign for Vehicle use. When driver is unable to communicate, alerts Emergency personnel child is inside	3986 1	1	6
▶ 3990	Foot Operated Door Stop: Hands free open and release door stop 9-1/2" (24cm) for interior use only.	3990 8	1	6

▶ Available Only in Canada



DESIGN TEAM PARTNERS

Help is available.....

When generic merchandisers miss the mark for your business, remember that Shepherd Hardware Products has an in-house design team available to provide assistance whenever special promotions, signage, labels, POP merchandisers, etc. are required.

Call your Sales Rep to inquire.



Aisle Violators
36" x 6-1/4"

Header Sign
9-3/4" x 47-7/8"



WHEEL TREES DISPLAY MERCHANDISERS

»»» Five Replacement Wheel Assortments Available



Flat-Free Wheels



Replacement Wheels



Replacement Wheels + Wheelbarrow



Wheelbarrow 1



Wheelbarrow 2

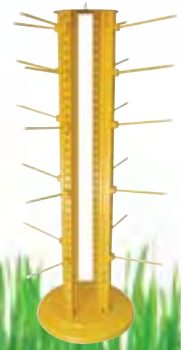

Empty Tree Stand

CLIP STRIPS, STACK-OUT TRAYS & P.O.P. / DISPLAYS

Clip Strips

ITEM #	DESCRIPTION	U.P.C. (0 39003)	PCS/ PKG	PKG/ CTN
★ 3039S	Cup Insert 1-1/4" (32mm) Plastic	03039 4	4	6
★ 3040S	Cup Insert 1-1/2" (38mm) Plastic	03040 0	4	6
★ 9468S	Slide Glide® Hex Base	99468 9	4	6
◆ 9471S	Slide Glide® Dinette Pack	99471 9	20	12
◆ 9947S	FeltGard® Heavy Duty Assortment	99947 9	27	12
◆ 9951S	FeltGard® 3/4" (19mm)	09951 3	20	12
★ 9952S	FeltGard® 1" (25mm)	99952 3	16	12
◆ 9953S	FeltGard® 1-1/2" (38mm)	09953 7	8	12
◆ 9964S	SurfaceGard® 3/8" Vinyl	99964 6	16	12
9967S	SurfaceGard® 1/2" Vinyl	99967 7	16	12

- ★ Not Stocked in Canada – Call for Lead-time
- ◆ Call for Lead-time

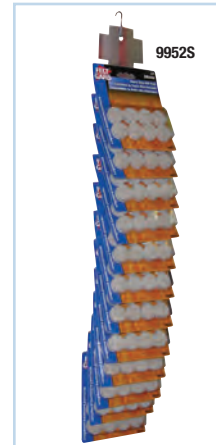

Merchandising Trays

ITEM #	DESCRIPTION	U.P.C. (0 39003)
▶ 9901	Tray Loaded with 52 Cards of 9951	09901 8
▶ 9902	Tray Loaded with 52 Cards of 9952	09902 5
▶ 9903	Tray Loaded with 52 Cards of 9953	09903 2

- ▶ Available Only in Canada

Point of Purchase Displays

ITEM #	DESCRIPTION	U.P.C. (0 39003)
▶ 6989	POWER PANEL 140 Cards. Heavy Duty FELT GARD® - Loaded with 30 Cards of 6927, 30 Cards of 6951, & 80 cards of 6952	N/A
▶ 6990	POWER PANEL 68 Cards. Heavy Duty FELT GARD® - Loaded with 20 Cards of 6927, 28 Cards of 9947D, & 20 cards of 9950	N/A
▶ 6991	POWER PANEL 120 Cards. Heavy Duty FELT GARD® - Loaded with 10 Cards of 6815, 10 Cards of 6816, 20 cards of 6927, 40 cards of 6952, & 40 Cards of 9913	N/A
▶ 6992	POWER PANEL 62 Cards. Heavy Duty FELT GARD® - Loaded with 10 Cards of 6927, 10 Cards of 6952, 10 Cards of 6953, 6 Cards of 9841, 4 Cards of 9842, 8 Cards of 9843, 14 Cards of 9947	N/A
▶ 6993	POWER PANEL 108 Cards. Heavy Duty FELT GARD® - Loaded with 18 Cards of 9951, 72 Cards of 9952, & 18 cards of 9953	N/A
▶ 9923	POWER PANEL Heavy Duty FELT GARD® - Loaded with 18 Cards of 9951 72 Cards of 9952, & 18 cards of 9953	N/A
★ 9968	POWER PANEL Loaded with 12 cards of 9421, 9423, 9433, 9560, 9561, 9562, 9563, 9565, 9820, 9821, 9949, 9956, 9957, 9958, 9959, 9960, 9961, 9962, 9965, 9967, 9973, 9974, & 24 cards of 9964	N/A
★ 9989	FLOOR DISPLAY Heavy Duty FELT GARD®- Includes 36 Cards of 9951, 90 Cards of 9952, & 24 cards of 9953	N/A
★ 9438	POWER PANEL SLIDE GLIDE® - Loaded with 6 Cards: 9221, 9240, 9241, 9249, 9453, 9456 & 12 Cards: 9222, 9452, 9455, 9469	N/A

- ★ Not Stocked in Canada – Call for Lead-time
- ▶ Available Only in Canada

WIRE RACKS



Slide Glide® Assortment Wire Rack Display

ITEM #	DESCRIPTION	U.P.C. (0 39003)	FAC- ING	QTY/ PNL
6426	Includes Wire Rack, 6 Hooks, Header Sign & Product Assortment			
Product Assortment contents:				
9221	2" (50mm) Pads	09221 7	1	4
9222	3/4" (19mm) Pads	09222 4	1	4
9241	1" (25mm) Pads	09241 5	1	8
9452	1-1/2" (38mm) Pads	09452 5	1	10
9453	Dinette Pack Pads	09453 2	1	7
9469	Variety Pack	09469 3	1	6



Heavy Duty Felt Assortment Wire Rack Display

ITEM #	DESCRIPTION	U.P.C. (0 39003)	FAC- ING	QTY/ PNL
6983	Includes Wire Rack, 6 Hooks, Header Sign & Product Assortment			
Product Assortment contents:				
6927	2" (50mm) Pads	06927 1	1	10
6951	3/4" (19mm) Pads	09951 3	1	10
6952	1" (25mm) Pads	09952 0	2	20
6953	1-1/2" (38mm) Pads	09953 7	1	10
9913	Dinette Pack Pads	09913 1	1	10
9947	Variety Pack	09947 6	1	7

Available Only in Canada



Slider n Gripper Wire Rack Display

ITEM #	DESCRIPTION	U.P.C. (0 39003)	FAC- ING	QTY/ PNL
3705	Includes Wire Rack, 6 Hooks, Header Sign & Product Assortment			
Product Assortment contents:				
3687	3-1/4" (82mm) Wood Effect Dual Function Furniture Pad	03687 7	1	4
3691	1" (25mm) Wood Effect Furniture Glide	03691 4	1	6
3692	1-1/4" (32mm) Non Slip Wood Effect Furniture Pad	03692 1	1	6
3693	2" (50mm) Wood Effect Non Slip Furniture Cup	03693 8	1	6
3694	3/4" (19mm) Wood Effect Furniture Glide	03694 5	1	6
3696	Large Caster Wood Effect 2-1/4" I.D. (56mm) Non Slip Furniture Cup	03696 9	1	4

Not Stocked in Canada – Call for Lead-time



Triangular Wire Racks

ITEM #	DESCRIPTION	U.P.C. (0 39003)
9581	TRIANGULAR WIRE DISPLAY: Panel A - 4 cards 9364, 6 cards 9645, 6 cards 9646, 12 cards 9815, 6 cards 9827, 6 cards 9828, 24 cards 9947, 12 cards 9950, 12 cards 9951, 24 cards 9952, 12 cards 9953, 12 cards 9954, 6 cards 9955 Panel B - 6 cards 9335, 6 cards 9336, 6 cards 9337, 6 cards 9338, 6 cards 9369, 6 cards 9431 Panel C - 6 cards 9221, 6 cards 9222, 6 cards 9240, 6 cards 9241, 6 cards 9243, 6 cards 9452, 6 cards 9453, 6 cards 9454, 12 cards 9455, 6 cards 9456, 12 cards 9469	N/A
9582	TRIANGULAR WIRE DISPLAY: Panel A - 12 cards 9815, 12 cards 9816, 12 cards 9818, 12 cards 9947, 12 cards 9950, 36 cards 9951, 60 cards 9952, 48 cards 9953, 12 cards 9954, 12 cards 9955 Panel B - 6 cards 9058, 4 cards 9364, 12 cards 9820, 12 cards 9821, 12 cards 9823, 6 cards 9825, 6 cards 9827, 6 cards 9828, 12 cards 9938, 12 cards 9957, 12 cards 9956, 12 cards 9958, 12 cards 9959, 12 cards 9962, 24 cards 9964, 12 cards 9965, 12 cards 9967, 12 cards 9974, 12 cards 9980, Panel C - 6 cards 9221, 12 cards 9222, 6 cards 9240, 6 cards 9241, 6 cards 9243, 12 cards 9452, 12 cards 9453, 6 cards 9454, 12 cards 9455, 12 cards 9456, 12 cards 9469	N/A
9583	TRIANGULAR WIRE DISPLAY: Panel A - 18 cards 9338, 6 cards 9336, 12 cards 9221, 12 cards 9222 Panel B - 12 cards 9369, 12 cards 9431 Panel C - 6 cards 9240, 6 cards 9241, 6 cards 9243, 6 cards 9244, 12 cards 9249, 12 cards 9452, 12 cards 9453, 12 cards 9454, 12 cards 9455, 12 cards 9456, 12 cards 9469	N/A

Not Stocked in Canada – Call for Lead-time

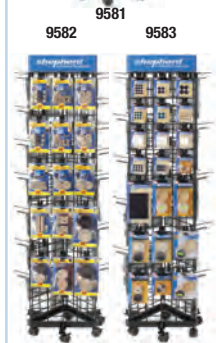

VALUE PACK ASSORTMENTS / DISPLAYS

8 pc Value Pack Combo

ITEM #	DESCRIPTION	U.P.C. (0 39003)	PCS/ PKG	PKG/ CTN
3960	3-1/2" Slide Glide Reusable Pads, 3-1/2" H-D FeltGard Reusable Pads	03690 1	8	4

Reusable Heavy Duty Felt Movers and Low Friction Sliders

FeltGard® heavy duty felt movers protect wood and hard surface flooring, while SLIDE GLIDE Plus® sliders remove the friction between your furniture and carpeting, permitting heavy objects to move safely without damage or excessive effort.

1. Four 3-1/2" FeltGard® mover pads
2. Four 3-1/2" Slide Glide® movers



12 pc 3-in-1 Value Pack

ITEM #	DESCRIPTION	U.P.C. (0 39003)	PCS/ PKG	PKG/ CTN
9855	4" I.D. Slide Glide Cups, 4" Anti-skid Pads, 4" H-D FeltGard Pads	09855 4	12	4

Each card contains twelve pads designed for three distinctly different surfaces or purposes.

1. Four anti-skid SurfaceGrip® pads minimize furniture movement, and reduce vibration and noise.
2. Four larger size self-adhesive FeltGard® pads available to protect hardwood, linoleum, ceramic tile and other hard surfaces.
3. Four Slide Glide® cups are simple to install to move objects smoothly on carpeted floors.



16 pc Easy Movers Pack

ITEM #	DESCRIPTION	U.P.C. (0 39003)	PCS/ PKG	PKG/ CTN
9045	Easy Mover Pack contains H-D FeltGard & Slide Glide movers	09045 9	16	4

SLIDE GLIDE® sliders remove the friction between your furniture and carpeting, and FeltGard® heavy duty felt movers protect wood and hard surface flooring. Both move heavy objects safely, without damage or excessive effort.

- 4 - 5-3/4" x 8" Slider Mover Pads
- 4 - 3-1/2" round Slider Mover Pads
- 4 - 4" x 7" Felt Mover Pads
- 4 - 3-1/2" round Felt Mover Pads



58 pc Combo Pack

ITEM #	DESCRIPTION	U.P.C. (0 39003)	PCS/ PKG	PKG/ CTN
9917	58 pc assortment of FeltGard & Slide Glide pads	09917 9	58	6

For wood or laminated surfaces
Self-Adhesive FeltGard® Pads and Sheets

- 16 — 1" (25mm) Round Pads
- 8 — 1-1/2" (38mm) Round Pads
- 16 — 1" (25mm) Square Pads
- 2 — 4-1/4" x 6" (108 x 150mm) Sheets

Easy moving sliders assortment for carpeted flooring. Attaches with screws and/or self-adhesive

- 4 — 2-1/2" (38mm) Round Pads
- 4 — 2" (38mm) Round Pads
- 4 — 1" (25mm) Round Pads



Available Only in Canada

VALUE PACK ASSORTMENTS

104 pc Value Pack Assortment

ITEM #	DESCRIPTION	U.P.C. (0 39003)	PCS/ PKG	PKG/ CTN
9065	104 pc FeltGard® & Slide Glide® assortment	09065 7	104	6

FeltGard® Contents

- 1 – 6" x 9" (15 x 23cm) Pads
- 12 – 1/2 x 2-5/8" (13x 67mm) Pads
- 24 – 3/4" (19mm) Pads
- 18 – 1" (25mm) Pads
- 16 – 1-1/2" (38mm) Pads

Slide Glide® Contents

- 24 – 1" (25mm) Pads
- 9 – 1-1/2" (38mm) Pads



118 pc Value Pack Assortment

ITEM #	DESCRIPTION	U.P.C. (0 39003)	PCS/ PKG	PKG/ CTN
9839	118 pc FeltGard assortment	09839 4	118	12

Self-Adhesive FeltGard®

- #### Pads, Strips & Sheets
- 72 — 1" (25mm) Round Pads
 - 20 — 3/4" (19mm) Round Pads
 - 9 — 1/2" x 6" (12mm x 150mm) Strips
 - 8 — 1-1/2" (38mm) Round Pads

- 8 — 3" (75mm) Round Pads
- 1 — 4-1/4 x 6" (108x150mm) Sheet



9839H

180 pc Surface Protection Kit

ITEM #	DESCRIPTION	U.P.C. (0 39003)	PCS/ PKG	PKG/ CTN
9046	180 pc assortment to protect multiple surfaces from scratches & dents	09046 6	180	6

Self-Adhesive FeltGard® Pads and Strips

- 28 — 3/4" (19mm) Round Pads
- 6 — 1-1/2" (38mm) Round Pads
- 24 — 1" (25mm) Round Pads
- 44 — 3/8" (10mm) Round Pads
- 18 — 1/2" x 2-5/8" (13mm x 67mm) Strips

Self-Adhesive Slide Glide + Pads

- 12 — 1" (25mm) Round Pads

Self-Adhesive Bumpers

- 24 — 1/2" (13mm) Clear Vinyl

Nail-on Tacks / Glides

- 8 — 5/8" (16mm) Round Tacks
- 8 — 7/8" (22mm) Round Glides

Anti-Skid Screw-in Pads

- 8 — 1" (25mm) Round Pads



194 pc Value Pack Assortment

ITEM #	DESCRIPTION	U.P.C. (0 39003)	PCS/ PKG	PKG/ CTN
9838	194 pc FeltGard®/SurfaceGard® assortment	09838 7	194	6

Self-Adhesive FeltGard® Pads, Strips & Sheets

- 20 — 3/4" (19mm) Round Pads
- 72 — 1" (25mm) Round Pads
- 8 — 1-1/2" (38mm) Round Pads
- 4 — 3" (75mm) Round Pads
- 9 — 1/2" x 6" (12mm x 150mm) Strips

- 1 — 4-1/4 x 6" (108x150mm) Sheet

Self-Adhesive Medium Duty Felt

- 48 — 3/8" (10mm) Round Pads

Self-Adhesive Bumpers

- 32 — 1/2" (12mm) Clear Vinyl



INDEX

Item Number	Description	UPC (039003)	Pcs. per Pk.	Pks./Ctn.	Package Type	Pkg. Wt (lb.)	Pkg. Height	Pkg. Width	Pkg. Depth	Carton Weight	Carton Height	Carton Width	Carton Depth	Carton Volume (feet)	Catalog Page
3005	LEG TIP: Plastic White - Round 1-1/4" (32mm) / Patio category	030059	4	6	Blister	0.11	4.56	3.63	1.88	0.66	5.00	3.00	11.50	0.13	35
3010	GLIDE: Internal Plastic White Round 3/4" - 7/8" (19-22mm) / Patio category	030103	4	6	Blister	0.05	4.56	2.63	1.06	0.32	5.25	3.00	8.50	0.08	35
3011	GLIDE: Internal Plastic White Round 7/8" - 1" (22-25mm) / Patio category	030110	4	6	Blister	0.06	4.56	2.63	1.06	0.38	5.25	3.00	8.50	0.08	35
3015	GLIDE: Internal Plastic White Round Dome 1" (25mm) / Patio category	030158	4	6	Blister	0.09	4.56	3.63	1.38	0.54	5.00	3.00	8.50	0.10	35
3020	GLIDE: Internal Plastic White Square 13/16" (21mm) / Patio category	030202	4	6	Blister	0.06	4.56	2.63	1.06	0.36	5.25	3.00	8.50	0.08	35
3025	GLIDE: Internal Vinyl Clear Round Bottom 5/8" (16mm) / Patio category	030257	4	6	Blister	0.15	4.56	3.63	1.88	0.88	5.00	4.00	11.50	0.13	35
3030	UMBRELLA HOLE RING SET: Clear Plastic / Patio category	030301	1	6	Blister	0.09	4.56	3.63	0.88	0.54	5.00	4.00	6.50	0.08	35
3039S	CUP: Plastic White - Round / 1-1/4" (32mm) / Patio category / Clip Strip	030394	4	6	Blister	0.09	4.56	3.63	1.38	0.51	5.00	4.00	8.50	0.10	35, 40
3040	CUP: Plastic White - Round 1-1/2" (38mm) / Patio category	030400	4	6	Blister	0.09	4.56	3.63	1.38	0.54	5.00	4.00	8.50	0.10	35
3040S	CUP: Plastic White - Round / 1-1/2" (38mm) / Patio category / Clip Strip	030400	4	6	Blister	0.09	4.56	3.63	1.38	0.54	5.00	4.00	8.50	0.10	35, 40
3123	CASTER: Polypropylene Industrial General-duty Rigid 6" (150mm)	031230	1	4	Bulk	5.99	7.50	4.00	6.75	25.10	9.75	12.00	10.00	0.68	NA
3124	CASTER: Polypropylene Industrial General-duty Swivel 6" (150mm)	031247	1	4	Bulk	5.14	7.25	4.00	6.00	21.80	9.75	12.00	10.00	0.68	NA
3131	CASTER: Swivel Mold-on Rubber 8" x 2" (200 x 50mm) 1400 Series	031315	1	2	Bulk	10.45	-	-	-	19.35	11.00	8.25	9.00	0.47	11
3133	CASTER: Rigid Mold-on Rubber 8" x 2" (200 x 50mm) 1400 Series	031339	1	2	Bulk	9.63	-	-	-	20.10	10.50	8.50	8.50	0.44	11
3164	CASTER: Mold On Polyurethane Steel Hub - Swivel 4" x 2" (100 x 50mm)	031643	1	4	Bulk	5.66	-	-	-	22.60	6.50	8.5	10.75	0.34	12
3166	CASTER: Mold On Polyurethane Steel Hub - Swivel 6" x 2" (150 x 50mm)	031667	1	4	Bulk	8.05	7.50	4	6.75	32.85	8.50	8.38	13.50	0.56	12
3167	CASTER: Mold On Polyurethane Steel Hub - Swivel 8" x 2" (200 x 50mm)	031674	1	2	Bulk	10.70	-	-	-	22.00	10.50	8.13	9.00	0.44	12
3172	CASTER: Mold On Polyurethane Steel Hub - Rigid 4" x 2" (100 x 50mm)	031728	1	4	Bulk	10.70	-	-	-	19.75	6.00	8.13	9.50	0.27	12
3174	CASTER: Mold On Polyurethane Steel Hub - Rigid 6" x 2" (150 x 50mm)	031742	1	4	Bulk	7.05	7.50	2	6	29.65	8.50	8.25	12.13	0.49	12
3175	CASTER: Mold On Polyurethane Steel Hub - Rigid 8" x 2" (200 x 50mm)	031759	1	2	Bulk	9.55	-	-	-	20.75	10.00	12.00	9.75	0.68	12
3201	LEG TIP: Rubber Bulk Black 1/2" (13mm)	032015	1	40	Bulk Poly	0.02	-	-	-	0.96	7.00	4.00	12.00	0.19	33
3202	LEG TIP: Rubber Bulk Black 5/8" (16mm)	032022	1	40	Bulk Poly	0.02	-	-	-	1.08	7.00	4.00	12.00	0.19	33
3203	LEG TIP: Rubber Bulk Black 3/4" (19mm)	032039	1	40	Bulk Poly	0.04	-	-	-	1.68	7.00	4.00	12.00	0.19	33
3204	LEG TIP: Rubber Bulk Black 7/8" (22mm)	032046	1	40	Bulk Poly	0.04	-	-	-	1.72	7.00	4.00	12.00	0.19	33
3205	LEG TIP: Rubber Bulk Black 1" (25mm)	032053	1	40	Bulk Poly	0.06	-	-	-	2.72	7.00	4.00	12.00	0.19	33
3206	LEG TIP: Rubber Bulk Black 1-1/8" (29mm)	032060	1	40	Bulk Poly	0.07	-	-	-	2.92	7.00	4.00	12.00	0.19	33
3207	LEG TIP: Rubber Bulk Black 1-1/4" (32mm)	032077	1	40	Bulk Poly	0.09	-	-	-	3.92	7.00	4.00	12.00	0.19	33
3208	LEG TIP: Rubber Bulk Black 1-1/2" (38mm)	032084	1	40	Bulk Poly	0.10	-	-	-	4.44	7.00	4.00	12.00	0.19	33
3210	LEG TIP: Rubber Bulk White 1/2" (13mm)	032107	1	40	Bulk Poly	0.02	-	-	-	0.96	7.00	4.00	12.00	0.19	33
3211	LEG TIP: Rubber Bulk White 5/8" (16mm)	032114	1	40	Bulk Poly	0.02	-	-	-	1.08	7.00	4.00	12.00	0.19	33
3212	LEG TIP: Rubber Bulk White 3/4" (19mm)	032127	1	40	Bulk Poly	0.04	-	-	-	1.68	7.00	4.00	12.00	0.19	33
3213	LEG TIP: Rubber Bulk White 7/8" (22mm)	032138	1	40	Bulk Poly	0.04	-	-	-	1.72	7.00	4.00	12.00	0.19	33
3214	LEG TIP: Rubber Bulk White 1" (25mm)	032145	1	40	Bulk Poly	0.06	-	-	-	2.72	7.00	4.00	12.00	0.19	33
3215	LEG TIP: Rubber Bulk White 1-1/8" (29mm)	032152	1	40	Bulk Poly	0.07	-	-	-	2.92	7.00	4.00	12.00	0.19	33
3216	LEG TIP: Rubber Bulk White 1-1/4" (32mm)	032169	1	40	Bulk Poly	0.09	-	-	-	3.92	7.00	4.00	12.00	0.19	33
3217	LEG TIP: Rubber Bulk White 1-1/2" (38mm)	032176	1	40	Bulk Poly	0.13	-	-	-	5.95	7.00	4.00	12.00	0.19	33
3330	REPLACEMENT WHEEL: Inner Tube 410/350x6 W/L" Valve Stem	033302	1	6	Clamshell	0.63	6.00	6.25	2.75	4.30	6.50	6.50	13.70	0.34	17
3331	REPLACEMENT WHEEL: Inner Tube 410/350x4 W/L" Valve Stem	033319	1	6	Clamshell	0.50	6.00	6.25	2.50	3.50	6.50	6.50	13.70	0.34	17
3332	REPLACEMENT WHEEL: Inner Tube 15/600x6 W/L" Valve Stem	033326	1	6	Clamshell	1.19	8.00	6.13	2.25	7.64	8.66	7.09	13.70	0.49	17
3333	REPLACEMENT WHEEL: Tire & Tube for 16" Wheelbarrow Wheel	033333	1	4	Tire Card	3.18	-	-	-	21.16	16.54	15.35	15.35	2.26	17
3334	REPLACEMENT WHEEL: Wheelbarrow 16" Tubeless Wheel	033340	1	4	Tire Card	7.27	-	-	-	-	12.50	31.00	16.00	3.59	17
3335	REPLACEMENT WHEEL: 10" 2 PLY Wheel Sawtooth Tread 4" Rim	033357	1	6	Hub Insert	3.72	-	-	-	-	12.50	21.25	10.50	1.61	17

Item Number	Description	UPC (039003)	Pcs. per Pk.	Pks./ Ctn.	Package Type	Pkg Wt. (lb.)	Pkg Height	Pkg Width	Pkg Depth	Carton Weight	Carton Height	Carton Width	Carton Depth	Carton Volume (cubic feet)	Catalog Page
3336	REPLACEMENT WHEEL: 480/400x8 Tubeless Tire	03336 4	1	4	Hub Insert	7.71	-	-	-	-	16.50	25.25	18.25	4.40	17
3337	REPLACEMENT WHEEL: 400x6 Tubeless Tire	03337 1	1	6	Hub Insert	5.17	-	-	-	-	13.00	27.00	11.50	2.34	17
3338	REPLACEMENT WHEEL: 480/400x8 Rib Tire	03338 8	1	6	Hub Insert	2.38	-	-	-	-	16.53	15.35	15.35	2.25	17
3339	REPLACEMENT WHEEL: 7" Offset Rib Tread	03339 5	1	12	Hub Insert	1.58	-	-	-	19.57	7.25	19.00	7.25	0.58	16
3340	REPLACEMENT WHEEL: 400x6 Rib Tread Tire	03340 1	1	6	Hub Insert	2.38	-	-	-	-	13.78	13.78	13.78	1.51	17
3345	REPLACEMENT WHEEL: 6" Solid Tire Diamond Tread Offset	03345 6	1	12	Hub Insert	1.70	-	-	-	20.90	6.25	19.00	6.25	0.43	16
3346	REPLACEMENT WHEEL: 8" Solid Tire Diamond Tread Offset	03346 3	1	12	Hub Insert	3.49	-	-	-	-	9.00	11.25	16.00	0.94	16
3350	REPLACEMENT WHEEL: 14x1.75 Spoke Wheel	03350 0	1	6	Hub Insert	-	-	-	-	-	14.00	14.00	14.00	1.59	16
3355	REPLACEMENT WHEEL: 8" Offset Gear Tread	03355 5	1	12	Hub Insert	-	-	-	-	-	9.00	11.25	16.00	0.94	16
3541	CASTER: 2" Swivel TPU Wheel	03451 2	-	24	Bulk	0.33	-	-	-	7.78	7.20	4.25	12.8	0.23	7
3542	CASTER: 2" Swivel with Brake TPU Wheel	03542 9	-	24	Bulk	0.37	-	-	-	8.74	7.20	4.25	12.8	0.23	7
3543	CASTER: 2" Rigid TPU Wheel	03543 6	-	24	Bulk	0.17	-	-	-	4.70	7.20	3.23	12.8	0.17	7
3545	CASTER: 3" Swivel TPR Wheel	03545 0	-	10	Bulk	0.74	-	-	-	7.34	7.20	4.25	12.8	0.23	7
3546	CASTER: 3" Swivel with Brake TPR Wheel	03546 7	-	10	Bulk	0.80	-	-	-	7.98	7.20	4.25	12.8	0.23	7
3547	CASTER: 3" Rigid TPR Wheel	03547 4	-	10	Bulk	0.56	-	-	-	5.60	7.20	4.25	12.8	0.23	7
3598	SURFACE GRIP: 2" x 4" Pads	03598 6	3	6	Blister	0.05	5.50	4.63	0.75	0.40	5.79	4.72	4.92	0.08	23
3600	SURFACE GRIP: 4-1/4" x 6" Pads	03600 6	2	6	Blister	0.11	8.75	5.63	0.47	0.94	9.06	3.35	5.91	0.10	23
3601	SURFACE GRIP: 3/4" Round Pads	03601 3	20	6	Blister	0.03	5.50	4.63	0.47	0.33	5.79	3.35	4.92	0.06	23
3602	SURFACE GRIP: 1" Round Pads	03602 2	16	6	Blister	0.04	5.50	4.63	0.47	0.37	5.79	3.35	4.92	0.06	23
3603	SURFACE GRIP: 1-1/2" Round Pads	03603 7	3	6	Blister	0.04	5.50	4.63	0.43	0.39	5.79	3.35	4.92	0.06	23
3608	SURFACE GRIP: 2-1/2" Round Pads	03608 2	4	6	Blister	0.04	5.50	4.63	1.06	0.47	5.79	6.30	4.92	0.10	23
3615	SURFACE GRIP: 1" Square Pads	03615 0	16	6	Blister	0.04	5.50	4.63	0.47	0.37	5.79	3.35	4.92	0.06	23
3616	SURFACE GRIP: 1-1/2" x 1-1/2" Pads	03616 7	8	6	Blister	0.04	5.50	4.63	0.47	0.40	5.79	3.35	4.92	0.06	23
3624	SURFACE GRIP: 1" x 3-3/4" Pads	03624 2	4	6	Blister	0.04	5.50	4.63	0.47	0.38	5.79	3.35	4.92	0.06	23
3627	SURFACE GRIP: 2" Round Pads	03627 3	4	6	Blister	0.04	5.50	4.63	0.47	0.34	5.79	2.80	4.92	0.05	23
3628	SURFACE GRIP: 3" Round Pads	03628 0	8	6	Blister	0.06	5.50	4.63	0.98	0.60	5.79	6.30	4.92	0.10	23
3633	FELT GARD PLUS: 7/8" (22mm) Round Pads	03721 8	8/8	6	Blister	0.08	5.50	4.63	0.95	0.68	5.71	4.92	6.29	0.10	21
3634	FELT GARD PLUS: 1" (25mm) Round Pads	03634 1	8/8	6	Blister	0.11	5.50	4.63	0.95	0.84	5.71	4.92	6.29	0.10	21
3635	FELT GARD PLUS: 1-1/2" (38mm) Round Pad	03635 8	4/4	6	Blister	0.098	5.50	4.63	1.14	0.76	5.71	4.92	7.67	0.13	21
3636	FELT GARD PLUS: 7/8" (22mm) Replacement Pads Only	03636 5	8	6	Blister	0.049	5.50	4.63	0.55	0.47	5.71	4.92	3.74	0.06	21
3637	FELT GARD PLUS: 1" (25mm) Replacement Pads Only	03637 2	8	6	Blister	0.056	5.50	4.63	0.55	0.51	5.71	4.92	3.74	0.06	21
3638	FELT GARD PLUS: 1-1/2" (38mm) Round Pad	03638 9	4	6	Blister	0.059	5.50	4.63	0.55	0.53	5.71	4.92	3.74	0.06	21
3687	SLIDER n GRIPPER: Wood Effect Dual Function Furniture Pad 3-1/4" (82mm)	03687 7	4	4	Blister	0.32	6.56	4.63	2.00	1.50	6.88	4.75	9.00	0.17	27
3691	SLIDER n GRIPPER: Wood Effect Furniture Glide 1" (25mm)	03691 4	8	6	Blister	0.10	5.50	4.63	0.87	0.78	5.88	5.00	6.00	0.10	27
3692	SLIDER n GRIPPER: Non Slip Wood Effect Furniture Pad 1-1/4" (32mm)	03692 1	8	6	Blister	0.16	5.50	4.63	0.86	1.10	5.75	5.00	6.13	0.10	27
3693	SLIDER n GRIPPER: Wood Effect Non Slip Furniture Cup 2" (50mm)	03693 8	4	6	Blister	0.20	5.50	4.63	1.07	1.40	5.75	5.00	8.50	0.10	27
3694	SLIDER n GRIPPER: Wood Effect Furniture Glide 3/4" (19mm)	03694 5	16	6	Blister	0.14	5.50	4.63	0.91	0.98	5.50	5.00	8.75	0.14	27
3696	SLIDER n GRIPPER: Large CASTER: Wood Effect Non Slip Furniture Cup 2-1/4" I.D. (56mm)	03696 9	4	4	Blister	0.37	6.56	4.63	1.90	1.70	6.75	5.00	9.00	0.18	27
3697	SLIDER n GRIPPER: Small CASTER: Wood Effect Non Slip Furniture Cup 1-3/4" I.D. (44mm)	03697 6	4	6	Blister	0.20	5.50	4.63	1.35	1.40	5.75	5.00	8.75	0.15	27
3705	SLIDER n GRIPPER: Wire Rack Display/includes hooks	-	40	1	Carton	-	-	-	-	-	-	-	-	-	27, 40
3762	DOOR STOP: Jumbo Heavy-Duty Door Wedge Black	03762 1	1	4	Blister	0.21	9.50	4.75	2.38	1.20	9.75	8.63	5.00	0.24	31
3763	DOOR STOP: Jumbo Heavy-Duty Door Wedge Yellow	03763 8	1	4	Blister	0.21	9.50	4.63	2.50	1.23	10.00	5.00	8.63	0.25	31

INDEX

Item Number	Description	UPC (039003)	Pcs. per Pk.	Pks./Ctn.	Package Type	Pkg. Wt (lb.)	Pkg. Height	Pkg. Width	Pkg. Depth	Carton Weight	Carton Height	Carton Width	Carton Depth	Carton	Cube (feet)	Catalog Page
3921	LEG TIP: 3/4" Plastic Leg Tips w/ Felt White	03921 2	4	6	Blister	0.04	4.56	3.63	1.00	0.36	4.88	6.25	3.88	0.68	0.68	34
3922	LEG TIP: 7/8" Plastic Leg Tips w/ Felt White	03922 9	4	6	Blister	0.05	4.56	3.63	0.88	0.42	4.88	6.25	3.88	0.68	0.68	34
3923	LEG TIP: 1" Plastic Leg Tips w/ Felt White	03923 6	4	6	Blister	0.06	4.56	3.63	0.88	0.46	4.88	6.25	3.88	0.68	0.68	34
3924	LEG TIP: 1-1/4" Plastic Leg Tips w/ Felt White	03924 3	4	6	Blister	0.08	4.56	3.63	1.38	0.67	5.00	8.88	3.75	0.96	0.96	34
3931	LEG TIP: 3/4" Plastic Leg Tips w/ Felt Black	03931 1	4	6	Blister	0.04	4.56	3.63	1.00	0.36	4.88	6.25	3.88	0.68	0.68	34
3932	LEG TIP: 7/8" Plastic Leg Tips w/ Felt Black	03932 8	4	6	Blister	0.05	4.56	3.63	0.88	0.42	4.88	6.25	3.88	0.68	0.68	34
3933	LEG TIP: 1" Plastic Leg Tips w/ Felt Black	03933 5	4	6	Blister	0.06	4.56	3.63	0.88	0.45	4.88	6.25	3.88	0.68	0.68	34
3934	LEG TIP: 1-1/4" Plastic Leg Tips w/ Felt Black	03934 2	4	6	Blister	0.08	4.56	3.63	1.38	0.65	5.00	8.88	3.75	0.96	0.96	34
3941	SLIDE GLIDE +/- 3/4" Round Self-Adhesive	03941 0	4	6	Blister	0.03	5.50	4.63	0.36	0.31	5.83	2.95	4.92	0.05	0.05	25
3942	SLIDE GLIDE +/- 1" Round Self-Adhesive	03942 7	4	6	Blister	0.04	5.50	4.63	0.36	0.35	5.83	2.95	4.92	0.05	0.05	25
3943	SLIDE GLIDE +/- 1-1/2" Round Self-Adhesive	03943 4	4	6	Blister	0.06	5.50	4.63	0.45	0.56	5.83	2.95	4.92	0.05	0.05	25
3944	SLIDE GLIDE +/- 2" Round Self-Adhesive	03944 1	4	6	Blister	0.08	5.50	4.63	0.73	0.61	5.71	5.12	4.92	0.08	0.08	25
3945	SLIDE GLIDE +/- 2-1/2" Round Self-Adhesive	03945 8	4	6	Blister	0.10	7.63	3.75	0.65	0.77	7.80	5.12	3.94	0.09	0.09	25
3946	SLIDE GLIDE: 2" x 2" x 2-1/2" Triangle Self-Adhesive	03946 5	4	6	Blister	0.08	5.50	4.63	0.79	0.62	5.71	5.12	4.92	0.08	0.08	25
3947	SLIDE GLIDE +/- 3-1/2" x 3-1/2" x 4-1/2" Triangle Self-Adhesive	03947 2	4	4	Blister	0.34	9.25	4.63	1.62	1.55	9.65	7.10	4.92	0.20	0.20	25
3948	SLIDE GLIDE +/- 1" Square Self-Adhesive	03948 9	4	6	Blister	0.05	5.50	4.63	0.40	0.36	5.71	2.68	4.92	0.04	0.04	25
3949	SLIDE GLIDE +/- 2" Square Self-Adhesive	03949 6	4	6	Blister	0.10	7.63	3.75	0.73	0.77	8.07	4.73	4.14	0.09	0.09	25
3950	SLIDE GLIDE +/- 1/2" x 4" Strip Self-Adhesive	03950 2	4	6	Blister	0.08	7.63	3.75	0.71	0.65	5.83	4.73	4.92	0.08	0.08	25
3951	SLIDE GLIDE +/- Value Pack 16 x 1" x 4 x 1-3/4" Round Self-Adhesive	03951 9	20	6	Blister	0.14	9.25	4.63	0.73	1.04	9.45	5.12	4.92	0.14	0.14	25
3953	SLIDE GLIDE +/- 1" Round Hollow Nail	03953 3	8	6	Blister	0.07	7.63	3.75	0.65	0.6	8.07	3.74	4.14	0.07	0.07	25
3955	SLIDE GLIDE +/- 3-1/2" Round / not Self-Adhesive / Store & Reuse	03955 7	4	4	Blister	0.20	9.25	4.63	1.18	1.01	9.65	5.12	4.92	0.14	0.14	25
3956	SLIDE GLIDE +/- 5" Square / not Self-Adhesive / Store & Reuse	03956 4	4	4	Blister	0.39	6.70	5.50	2.44	1.76	7.10	10.27	5.91	0.25	0.25	25
3957	SLIDE GLIDE +/- Value Pack 5-3/4 x 8" & 4 x 3-1/2" Round / not Self-Adhesive / Store & Reuse	03957 1	8	4	Blister	0.82	8.86	10.88	2.58	0.83	8.27	11.03	11.42	0.60	0.60	25
3958	SLIDE GLIDE +/- 2-1/2" x 9" Rectangle / not Self-Adhesive / Store & Reuse	03958 8	4	4	Blister	0.42	12.8	5.50	1.10	1.80	13.19	5.91	4.73	0.21	0.21	25
3960	FELT GARD: 3-1/2" (89mm) Slider Value Pack	03960 1	8	4	Blister	0.40	9.75	5.63	2.80	1.70	11.40	10.20	5.80	0.39	0.39	42
3970	SAFE KIDS: Safety Starter Pack w/Re-useable Storage Box, 6 Drawer Safety Latches, 10 Socket Safety Plugs, 8 Corner Cushions, 1 Fridge/ Freezer Latch, 1 Safety Door Stop	03970 0	24	6	Bumpa Box	0.77	5.12	7.68	2.91	5.07	16.14	8.27	5.91	0.46	0.46	38
3971	SAFE KIDS: Safety Latches Pull Open Door or Drawer Slightly, Press Down On the Hook to Open. Automatically Locks when Door or Drawer Closes.	03971 7	6	6	Clamshell	0.15	6.81	3.11	1.38	1.15	9.06	3.54	7.28	0.14	0.14	38
3972	SAFE KIDS: Spring Latches Pull Open Door or Drawer Slightly, Press Down On the Hook to Open. Automatically Locks when Door or Drawer Closes.	03972 4	3	6	Clamshell	0.19	7.20	3.46	1.77	1.34	11.02	3.94	7.56	0.19	0.19	38
3973	SAFE KIDS: Cupboard Slide Lock Suitable for Use with Most Mushroom Shaped Knobs and 'D' Handles. Fits Stem Depths and Diameters up to 3/4" (16mm) and up to 3-3/4" (96mm) Apart.	03973 1	1	6	Clamshell	0.12	6.81	3.11	1.38	0.93	9.06	3.54	7.28	0.14	0.14	38
3974	SAFE KIDS: Cupboard Slide Lock - Long Suitable for use with Most Mushroom Shaped Knobs and 'D' Handles. Extra Long Length Secures Handles and Knobs Up to 8-1/4" (210mm) apart.	03974 8	1	6	Clamshell	0.17	13.19	3.86	0.59	1.28	4.33	4.13	13.78	0.14	0.14	38
3975	SAFE KIDS: Flexible Lock Suitable for Use with Mushroom Shaped Knobs or 'D' Handles. Extra Long Length Straps Secure Handles & Knobs Up to 210mm (8-1/4") Apart.	03975 5	1	6	Clamshell	0.19	13.19	3.86	0.59	1.34	4.33	4.13	13.78	0.14	0.14	38
3976	SAFE KIDS: Flexi-Latches ideal for Appliance Doors, Toilet Seats and all Types of Furniture Cabinets.	03976 2	2	6	Clamshell	0.10	6.89	3.11	0.94	0.84	6.22	3.35	7.09	0.09	0.09	38
3977	SAFE KIDS: Flexi-Latches - Long Ideal for Appliance Doors, Toilet Seats and All Types of Furniture Cabinets.	03977 9	1	6	Clamshell	0.09	9.25	3.07	0.79	0.75	5.12	3.54	9.84	0.10	0.10	38
3978	SAFE KIDS: Angle Lock. Locks Automatically when Drawer Closes.	03978 6	2	6	Clamshell	0.17	6.89	3.86	2.48	1.28	15.35	4.33	7.09	0.27	0.27	38
3979	SAFE KIDS: Corner Cushions Applies with Double-sided Tape Onto the Furniture Corners.	03979 3	4	6	Clamshell	0.15	6.81	3.11	1.38	1.15	9.06	3.54	7.28	0.14	0.14	38
3980	SAFE KIDS: Fridge & Freezer Latch (May be Suitable for Other Appliances)	03980 9	1	6	Clamshell	0.08	9.25	3.07	0.79	0.71	5.12	3.54	9.84	0.10	0.10	38
3981	SAFE KIDS: Outlet Plugs. Covers Unprotected Electrical Outlets	03981 6	12	6	Clamshell	0.09	6.81	3.11	1.38	0.79	9.06	3.54	7.28	0.14	0.14	38
3982	SAFE KIDS: Cord Wind-Ups Safely Secures Long Cords on Blinds and Window Curtains	03982 3	2	6	Clamshell	0.11	6.81	3.11	1.38	0.88	9.06	3.54	7.28	0.14	0.14	38
3983	SAFE KIDS: Safety Door Stop - Prevents Interior Doors from Unintentionally Closing	03983 0	1	6	Clamshell	0.08	6.06	4.57	1.10	0.68	7.09	4.92	6.69	0.14	0.14	38

Item Number	Description	UPC (039003)	Pcs. per Pk.	Pks./ Ctn.	Package Type	Pkg Wt. (lb.)	Pkg Height	Pkg Width	Pkg Depth	Carton Weight	Carton Height	Carton Width	Carton Depth	Carton	Cube (feet)	Catalog Page
3984	SAFE KIDS: Bath Thermometer - Avoid Scalds and Ensures Baby's Comfort	03984 7	1	6	Clamshell	0.11	9.25	3.07	0.79	0.80	5.12	3.35	9.45	0.07	0.07	38
3985	SAFE KIDS: Bath Grip Applicques - Heat Sensing/Dual Function - Prevents Slips or Falls Color Changes when Water Temperature is too Hot.	03985 4	12	6	Clamshell	0.14	7.60	6.77	0.59	1.04	3.74	7.09	7.87	0.12	0.12	38
3986	SAFE KIDS: Baby on Board Sign for Vehicle use. Alerts Emergency Personnel Child is Inside Vehicle if driver is unable to communicate	03986 1	1	6	Clamshell	0.15	7.60	6.77	0.59	1.05	3.74	7.09	7.87	0.12	0.12	38
3990	SAFE KIDS: Foot Operated Door Stop. Clamshell Package	03990 8	1	6	Clamshell	0.21	10.63	3.13	1.50	1.59	3.15	10.24	9.45	0.18	0.18	38
4952	HOOK & LOOP: 7/8" (22mm) - white round	04952 5	12/12	6	Blister	0.05	7.21	4.63	0.35	0.36	7.68	5.04	2.48	0.06	0.06	19
4953	HOOK & LOOP: 7/8" (22mm) -black round	04953 2	12/12	6	Blister	0.05	7.21	4.63	0.35	0.36	7.68	5.04	2.48	0.06	0.06	19
4963	HOOK & LOOP: 1" x 11-3/4" (25 x 300mm) - white tape	04963 1	1/1	6	Blister	0.05	7.21	4.63	0.35	0.38	7.68	5.04	2.48	0.06	0.06	19
4964	HOOK & LOOP: 1" x 11-3/4" (25 x 300mm) - black tape	04964 8	1/1	6	Blister	0.05	7.21	4.63	0.35	0.38	7.68	5.04	2.48	0.06	0.06	19
4978	HOOK & LOOP: 1/2" x 8" (12 x 200mm) - black straps	04978 5	5	6	Blister	0.06	11.22	4.63	0.28	0.50	11.42	5.04	2.76	0.09	0.09	19
4980	HOOK & LOOP: 1/2" x 4" (12 x 110mm) - black straps	04980 8	5	6	Blister	0.04	7.21	4.63	0.26	0.30	7.68	5.04	2.48	0.06	0.06	19
6815	FELT GARD: H-D Felt 1" (25mm) Square Pad	06815 1	16	12	Blister	0.04	3.75	4.68	0.47	0.73	4.13	5.12	6.30	0.08	0.08	NA
6816	FELT GARD: H-D Felt 1-1/2" x 1-1/2" (38 x 38mm) Corner Pad	06816 8	8	12	Blister	0.06	3.75	4.68	0.91	0.84	4.13	5.12	11.22	0.14	0.14	NA
6844	FELT GARD: Self-adhesive Felt Pad 1" x 3-3/4" (25 x 95mm)	06844 1	4	12	Blister	0.05	3.75	4.68	0.47	0.73	4.13	5.12	6.30	0.08	0.08	NA
6927	FELT GARD: Heavy-Duty Felt 2" (50mm) Pads Self-Adhesive	06927 1	4	6	Blister	0.06	3.75	4.68	0.47	0.73	4.13	3.15	5.12	0.04	0.04	NA
6937	FELT GARD: 1/2" x 2-3/8" Self-Adhesive Strip Pads	06937 0	16	6	Blister	0.07	3.75	4.68	0.47	0.73	4.13	3.15	5.12	0.04	0.04	NA
6951	FELT GARD: Heavy-Duty Felt 3/4" (19mm) Pad Self-Adhesive	06951 6	20	12	Blister	0.05	3.75	4.68	0.47	-	4.13	5.12	6.30	0.07	0.07	NA
6952	FELT GARD: Heavy-Duty Felt 1" (25mm) Pad Self-Adhesive	06952 3	16	12	Blister	0.06	3.75	4.68	0.47	-	4.13	5.12	6.30	0.07	0.07	NA
6953	FELT GARD: Heavy-Duty Felt 1-1/2" (38mm) Pad Self-Adhesive	06953 0	8	12	Blister	0.06	3.75	4.68	0.47	-	4.13	5.12	6.30	0.07	0.07	NA
6972	FELT GARD: 1" (25mm) Pad Bonus Pack	06972 8	48	6	Blister	0.13	3.75	4.68	-	-	-	-	-	-	-	NA
6989	FELT GARD: Power Panel Assortment	NA	140	1	Power Panel	-	-	-	-	13.35	38.00	13.00	6.50	1.86	4.0	40
6990	FELT GARD: Power Panel Assortment	NA	68	1	Power Panel	-	-	-	-	15.00	38.00	13.00	6.50	1.86	4.0	40
6991	FELT GARD: Power Panel Assortment	NA	120	1	Power Panel	-	-	-	-	13.00	38.00	13.00	6.50	1.86	4.0	40
6992	FELT GARD: Power Panel Assortment	NA	62	1	Power Panel	-	-	-	-	12.20	38.00	13.00	6.50	1.86	4.0	40
6993	FELT GARD: Power Panel Assortment	NA	108	1	Power Panel	-	-	-	-	12.00	38.00	13.00	6.50	1.86	4.0	40
8199	DOLLY WIRE PLANTER: Chrome Finish - 3 Wheels 11-1/4" (285mm)	08199 0	1	4	Label	1.31	2.50	11.00	11.00	6.39	6.00	12.00	12.00	0.50	18	18
8199W	DOLLY WIRE PLANTER: Chrome Finish - 3 Wheels 11-1/4" (285mm)	08199 0	1	4	Label	1.31	2.50	11.00	11.00	27.00	76.00	76.00	161.00	538.16	18	18
89851	MOVERS BLANKET: - Polybagged 72" x 80" (183 x 203cm)	89851 2	1	5	Poly Bag	6.00	-	-	-	40.50	14.50	19.25	21.00	3.39	36	36
9021	FELT GARD: 3/8" (10mm) Self-Adhesive Round Pads	09021 3	75	12	Blister	0.05	4.56	3.63	0.38	0.64	6.00	4.75	9.00	0.15	28	28
9034	CASTER: Soft Rubber 4" (100mm) w/brake Threaded Stem 1/2" x 1-1/2" (10mm x 38mm)	09034 3	1	6	Blister	1.29	6.10	4.72	2.20	8.15	3.74	11.02	8.27	0.20	9	9
9040	CASTER: Light-duty Plastic 2" (50mm) Wheel White - Stem 04	09040 4	2	6	Blister	0.51	6.56	4.63	2.00	3.04	7.00	4.75	13.00	0.25	6	6
9041	CASTER: Light-duty Plastic Wheel White 2" (50mm) - Plate 1-3/16" x 2" (30 x 50mm)	09041 1	2	6	Blister	0.54	6.56	4.63	2.00	3.26	7.00	4.75	13.00	0.25	6	6
9045	Easy Mover Pack contains H-D Felt Gard & SlideGlide movers 16 pcs	09045 9	16	4	Clamshell	1.59	-	-	-	-	-	-	-	-	42	42
9046	Surface Protection Assortment Kit 180 pcs	09046 6	180	6	Clamshell	0.67	9.125	7.25	1.50	-	-	-	-	-	43	43
9048	CASTER: Piano: Soft Rubber Wheel 2" (50mm) - Copper Oxide Plate	09048 7	1	40	Blister	2.00	2.75	2.50	3.75	80.00	8.00	8.00	14.75	0.55	8	8
9051	CASTER: Wood Wheel 1-5/8" (40mm) - Stem 02	09051 0	2	6	Blister	0.41	5.56	4.63	1.75	2.46	6.00	4.75	11.25	0.19	6	6
9052	CASTER: Light-duty Plastic Wheel White 1-1/4" (32mm) - Plate 1-3/16" x 1-3/4" (30 x 44mm)	09052 7	4	6	Blister	0.42	6.56	4.63	1.25	2.54	7.00	4.75	11.00	0.21	6	6
9053	CASTER: Light-duty Plastic Wheel White 1-1/4" (32mm) - Stem 02	09053 4	4	6	Blister	0.44	6.56	4.63	1.5	2.66	7.00	4.75	11.00	0.21	6	6
9054	CASTER: Light-duty Plastic Wheel White 1-5/8" (40mm) - Plate 1-3/16" x 1-3/4" (30 x 44mm)	09054 1	4	6	Blister	0.56	6.56	4.63	1.62	3.38	7.00	4.75	11.00	0.21	6	6
9055	CASTER: Light-duty Plastic Wheel White 1-5/8" (40mm) - Stem 02	09055 8	4	6	Blister	0.59	6.56	4.63	1.62	3.52	7.00	4.75	11.00	0.21	6	6
9056	CUP: Spiked Caster Cups for Bed Frame Caster 2-1/4" I.D. (56mm)	09056 5	4	6	Blister	0.38	9.87	4.88	0.75	1.59	10.20	5.51	5.87	0.19	30	30

INDEX

Item Number	Description	UPC (039003)	Pcs. per Pk.	Pks./Ctn.	Package Type	Pkg. Wt. (lb.)	Pkg. Height	Pkg. Width	Pkg. Depth	Carton Weight	Carton Height	Carton Width	Carton Depth	Carton	Cube (feet)	Catalog Page
9058	CUP: Light Woodgrain Effect w/Non Slip TPR base - Round 2-3/8" (60mm)	090589	4	6	Blister	0.35	8.5	4.38	1.63	2.10	7.00	6.00	11.00	0.27	30	30
9059	CUP: Dark Woodgrain Effect w/Non Slip TPR base - Round 1-3/4" (44mm)	090596	4	6	Blister	0.26	6.75	4.75	1.50	1.54	7.00	5.00	11.00	0.22	30	30
9060	CUP: Dark Woodgrain Effect w/Non Slip TPR base - Round 2-3/8" (60mm)	090602	4	6	Blister	0.35	6.75	5.75	1.63	2.10	7.00	6.00	11.00	0.27	30	30
9064	SOCKET: Plastic 1/2" (13mm)	090640	4	6	Blister	0.06	4.56	2.63	0.88	0.36	5.00	4.00	6.50	0.08	5	5
9065	Value Pack FeltGuard® & SlideGlide® assortment 104 pcs	090657	104	6	Clamshell	0.71	-	-	-	-	-	-	-	-	-	43
9066	SOCKET: Plastic 5/8" (16mm)	090664	4	6	Blister	0.07	4.56	2.63	0.88	0.42	5.00	4.00	6.50	0.08	5	5
9069	SOCKET: Plastic 3/4" (19mm)	090695	4	6	Blister	0.08	4.56	2.63	0.88	0.50	5.00	4.00	6.50	0.08	5	5
9071	SOCKET: Plastic 7/8" (22mm)	090718	4	6	Blister	0.11	4.56	2.63	1.88	0.64	5.00	4.00	11.50	0.13	5	5
9073	SOCKET: Plastic 1" (25mm)	090732	4	6	Blister	0.11	4.56	3.63	1.88	0.68	5.00	4.00	11.50	0.13	5	5
9074	CUP: Rubber Brown - Square 1-5/8" (40mm)	090749	4	6	Blister	0.32	6.56	3.63	1.88	1.94	5.00	4.00	11.50	0.13	30	30
9075	CUP: Rubber Brown - Round 1-1/2" (38mm)	090756	4	6	Blister	0.23	6.56	3.63	1.88	1.38	5.00	4.00	11.50	0.13	30	30
9076	CUP: Rubber Brown - Square 2" (50mm)	090763	4	6	Blister	0.51	6.56	4.63	1.13	3.04	7.00	4.75	7.50	0.14	30	30
9077	CUP: Rubber Brown - Round 1-3/4" (44mm)	090770	4	6	Blister	0.33	6.56	3.63	1.00	1.98	7.00	4.75	7.50	0.14	30	30
9078	CUP: Rubber Brown - Square 3" (75mm)	090787	2	6	Blister	0.33	6.56	4.63	1.5	1.98	7.00	4.75	7.50	0.14	30	30
9079	CUP: Carpet - Round 3" (75mm)	090794	4	6	Blister	0.28	5.56	4.63	1.63	1.68	6.00	4.75	11.25	0.19	30	30
9080	CUP: Carpet - Square 1-7/8" (48mm)	090800	4	6	Blister	0.20	4.56	3.63	1.5	1.18	5.00	4.00	8.50	0.10	30	30
9081	CUP: Spike Plastic Clear - Round 1-1/2" (38mm)	090817	4	6	Blister	0.15	6.56	3.63	2.5	0.90	7.00	4.75	11.00	0.21	30	30
9082	CUP: Spike Plastic Clear - Round 1-7/8" (48mm)	090824	4	6	Blister	0.19	6.56	3.63	1.13	1.14	7.00	4.75	7.50	0.14	30	30
9083	CUP: Spike Plastic Clear - Square 1-7/8" (48mm)	090831	4	6	Blister	0.22	6.56	3.63	1.13	1.30	7.00	4.75	7.50	0.14	30	30
9087	CUP: Smooth Plastic Clear - Round 1-7/16" (36mm)	090879	4	6	Blister	0.11	6.56	3.63	1.88	0.68	5.00	4.00	11.50	0.13	30	30
9088	CUP: Smooth Plastic Clear - Round 1-7/8" (48mm)	090886	4	6	Blister	0.14	6.56	3.63	1.88	0.84	5.00	4.00	11.50	0.13	30	30
9089	CUP: Smooth Plastic Clear - Square 1-7/8" (48mm)	090893	4	6	Blister	0.17	6.56	3.63	1.88	1.00	5.00	4.00	11.50	0.13	30	30
9090	CUP: Carpet - Round 1-1/4" (32mm)	090909	4	6	Blister	0.13	4.56	3.63	1.38	0.76	5.00	4.00	8.50	0.10	30	30
9091	CUP: Carpet - Round 2" (50mm)	090916	4	6	Blister	0.19	4.56	3.63	1.38	1.14	5.00	4.00	8.50	0.10	30	30
9092	CUP: Carpet - Round 2-1/2" (64mm)	090923	4	6	Blister	0.28	5.56	4.63	1.63	1.68	6.00	4.75	11.25	0.19	30	30
9094	GLIDE: Swivel Brass Plated 5/8" (16mm) I.D.	090947	4	6	Blister	0.10	4.56	3.63	1.38	0.62	5.00	4.00	8.50	0.10	26	26
9095	GLIDE: Swivel Brass Plated 3/4" (19mm) I.D.	090954	4	6	Blister	0.11	4.56	3.63	1.38	0.66	5.00	4.00	8.50	0.10	26	26
9096	GLIDE: Swivel Brass Plated 7/8" (22mm) I.D.	090961	4	6	Blister	0.12	4.56	3.63	1.38	0.74	5.00	4.00	8.50	0.10	26	26
9097	GLIDE: Swivel Brass Plated 1" (25mm) I.D.	090978	4	6	Blister	0.13	4.56	3.63	1.38	0.76	5.00	4.00	8.50	0.10	26	26
9098	GLIDE: Swivel Brass Plated / Nail-On 1" (25mm)	090985	4	6	Blister	0.11	4.56	3.63	1.38	0.66	5.00	4.00	8.50	0.10	26	26
9099	GLIDE: Metal Cushion Nail-On 7/8" (22mm)	090992	4	6	Blister	0.10	4.56	2.63	1.38	0.62	5.25	3.00	8.50	0.08	26	26
9100	GLIDE: Metal Cushion Nail-On 1-1/16" (27mm)	091005	4	6	Blister	0.12	4.56	2.63	1.38	0.72	5.25	3.00	8.50	0.08	26	26
9101	GLIDE: Metal Cushion Nail-On 1-1/4" (32mm)	091012	4	6	Blister	0.15	4.56	3.63	1.38	0.90	5.00	4.00	8.50	0.10	28	28
9102	GLIDE: Plastic Nail-On 7/8" (22mm)	091029	4	6	Blister	0.05	4.56	2.63	1.38	0.32	5.25	3.00	8.50	0.08	26	26
9103	GLIDE: Carpet Nail-On 1" (25mm)	091036	4	6	Blister	0.08	4.56	2.63	1.06	0.46	5.25	3.00	8.50	0.08	26	26
9105	LEG TIP: Plastic White - Round 1/2" (13mm)	091050	4	6	Blister	0.04	4.56	2.63	1.06	0.26	5.25	3.00	5.75	0.05	32	32
9106	LEG TIP: Plastic White - Round 5/8" (16mm)	091067	4	6	Blister	0.05	4.56	2.63	1.06	0.32	5.25	3.00	8.50	0.08	32	32
9107	LEG TIP: Plastic White - Round 3/4" (19mm)	091074	4	6	Blister	0.05	4.56	2.63	1.06	0.30	5.25	3.00	8.50	0.08	32	32
9108	LEG TIP: Plastic White - Round 7/8" (22mm)	091081	4	6	Blister	0.07	4.56	2.63	1.38	0.42	5.00	3.00	8.50	0.10	32	32
9109	LEG TIP: Plastic White - Round 1" (25mm)	091098	4	6	Blister	0.06	4.56	2.63	1.38	0.38	5.00	3.00	8.50	0.10	32	32
9111	LEG TIP: Plastic Black - Round 1/2" (13mm)	091111	4	6	Blister	0.04	4.56	2.63	1.06	0.24	5.25	3.00	5.75	0.05	32	32

Item Number	Description	UPC (039003)	Pcs. per Pk.	Pks./ Ctn.	Package Type	Pkg Wt. (lb.)	Pkg Height	Pkg Width	Pkg Depth	Carton Weight	Carton Height	Carton Width	Carton Depth	Carton Cube (feet)	Catalog Page
9112	LEG TIP: Plastic Black - Round 5/8" (16mm)	091128	4	6	Blister	0.05	4.56	2.63	1.06	0.28	5.25	3.00	8.50	0.08	32
9113	LEG TIP: Plastic Black - Round 3/4" (19mm)	091135	4	6	Blister	0.05	4.56	2.63	1.06	0.32	5.25	3.00	8.50	0.08	32
9114	LEG TIP: Plastic Black - Round 7/8" (22mm)	091142	4	6	Blister	0.06	4.56	2.63	1.38	0.38	5.00	3.00	8.50	0.10	32
9115	LEG TIP: Plastic Black - Round 1" (25mm)	091159	4	6	Blister	0.07	4.56	2.63	1.38	0.40	5.00	3.00	8.50	0.10	32
9117	LEG TIP: Rubber Off-White - Round 1/2" (13mm)	091173	4	6	Blister	0.14	4.56	3.63	1.38	0.82	5.00	4.00	8.50	0.10	33
9118	LEG TIP: Rubber Off-White - Round 5/8" (16mm)	091180	4	6	Blister	0.15	4.56	3.63	1.38	0.90	5.00	4.00	8.50	0.10	33
9119	LEG TIP: Rubber Off-White - Round 3/4" (19mm)	091197	4	6	Blister	0.21	4.56	3.63	1.38	1.26	5.00	4.00	8.50	0.10	33
9120	LEG TIP: Rubber Off-White - Round 7/8" (22mm)	091203	4	6	Blister	0.24	5.56	4.63	1.38	1.42	6.00	4.75	9.00	0.15	33
9121	LEG TIP: Rubber Off-White - Round 1" (25mm)	091210	4	6	Blister	0.34	5.56	4.63	1.63	2.06	6.00	4.75	11.25	0.19	33
9122	LEG TIP: Rubber Off-White - Round 1-1/8" (29mm)	091227	4	6	Blister	0.36	5.56	4.63	1.63	2.14	6.00	4.75	11.25	0.19	33
9123	LEG TIP: Rubber Black - Round 3/8" (10mm)	091234	4	6	Blister	0.11	4.56	2.63	1.38	0.82	5.00	3.00	8.50	0.08	33
9124	LEG TIP: Rubber Black - Round 1/2" (13mm)	091241	4	6	Blister	0.14	4.56	3.63	1.38	0.82	5.00	4.00	8.50	0.10	33
9125	LEG TIP: Rubber Black - Round 5/8" (16mm)	091258	4	6	Blister	0.15	4.56	3.63	1.38	0.88	5.00	4.00	8.50	0.10	33
9126	LEG TIP: Rubber Black - Round 3/4" (19mm)	091265	4	6	Blister	0.2	4.56	3.63	1.38	1.20	5.00	4.00	8.50	0.10	33
9127	LEG TIP: Rubber Black - Round 7/8" (22mm)	091272	4	6	Blister	0.23	5.56	4.63	1.38	1.40	6.00	4.75	9.00	0.15	33
9128	LEG TIP: Rubber Black - Round 1" (25mm)	091289	4	6	Blister	0.33	5.56	4.63	1.63	2.00	6.00	4.75	11.25	0.19	33
9129	LEG TIP: Rubber Black - Round 1-1/8" (29mm)	091296	4	6	Blister	0.34	5.56	4.63	1.63	2.04	6.00	4.75	11.25	0.19	33
9131	BUMPER: Screw Off-White Rubber 7/8" (22mm)	091319	4	6	Blister	0.09	4.56	2.63	0.75	0.54	5.25	3.00	8.50	0.08	29
9132	DOOR STOP: Wedge Brown	091326	2	6	Blister	0.22	6.56	3.63	1.5	1.34	7.00	4.75	8.50	0.16	31
9133	DOOR STOP: H-D Wedge Brown	091333	1	6	Blister	0.23	6.56	3.63	1.25	1.38	7.00	4.75	8.50	0.16	31
9135	BUMPER: Tack Black 5/8" (16mm)	091357	4	6	Blister	0.05	4.56	2.63	0.88	0.28	5.25	3.00	8.50	0.08	29
9140	FELT GARD: 5" (125mm) Round Pads Felt w/ thick 1/2" Black EVA foam	091401	4	4	Blister	0.38	13.00	6.00	1.50	1.85	13.25	6.25	6.00	0.29	21
9141	FELT GARD: 2-1/2" x 9" (64 x 225mm) Rectangular Pads Felt w/ thick 1/2" Black EVA foam	091418	4	4	Blister	0.41	13.00	6.00	1.50	1.95	13.25	6.25	6.00	0.29	21
9142	FELT GARD: 4" x 7" (100 x 175mm) Pads Felt w/ thick 1/2" Black EVA foam	091425	4	4	Blister	0.47	9.75	5.50	2.50	2.20	10.00	11.50	5.75	0.38	21
9143	GLIDE: Plastic Nail-On 5/8" (16mm)	091432	4	6	Blister	0.05	4.56	2.63	1.06	0.28	5.25	3.00	8.50	0.08	26
9144	GLIDE: Plastic Nail-On 3/4" (19mm)	091449	4	6	Blister	0.05	4.56	2.63	1.38	0.32	5.25	3.00	8.50	0.08	26
9145	CASTER: 1-1/4" White Wheel Plate	091456	1	24	Bulk	0.09	-	-	-	3.00	4.72	3.15	5.91	0.05	NA
9146	CASTER: 1-1/4" White Wheel Stem	091463	1	24	Bulk	0.08	-	-	-	3.00	3.94	3.15	5.91	0.04	NA
9147	CASTER: 1-1/4" Black Wheel Plate	091470	1	24	Bulk	0.09	-	-	-	3.00	4.72	3.15	5.91	0.05	NA
9148	CASTER: 1-1/4" Black Wheel Stem	091487	1	24	Bulk	0.09	-	-	-	3.00	3.94	3.15	5.91	0.04	NA
9151	BUMPER: Screw Grey Plastic 3/4" (19mm)	091517	4	6	Blister	0.05	4.56	2.63	0.56	0.32	5.25	3.00	5.75	0.05	29
9153	DOOR STOP: Foot operated door stop packaged on card	091531	1	6	Blister	0.23	11.00	4.63	1.88	1.71	5.12	11.42	5.91	0.02	31
9155	GLIDE: Carpet Nail-On 1-1/4" (32mm)	091555	4	6	Blister	0.11	4.56	2.63	1.38	0.66	5.00	4.00	8.50	0.10	26
9162	DOOR STOP: Wedge Off-White	091623	2	6	Blister	0.23	6.56	3.63	1.13	1.36	7.00	4.75	8.50	0.16	31
9163	DOOR STOP: H-D Wedge Off-White	091630	1	6	Blister	0.23	6.56	3.63	1.50	1.38	7.00	4.75	8.50	0.16	31
9164	CUP: Rubber Off-White - Square 1-5/8" (40mm)	091647	4	6	Blister	0.32	6.56	3.63	1.88	1.94	5.00	4.00	11.50	0.13	30
9165	CUP: Rubber Off-White - Round 1-1/2" (38mm)	091654	4	6	Blister	0.23	6.56	3.63	1.88	1.38	5.00	4.00	11.50	0.13	30
9166	CUP: Rubber Off-White - Square 2" (50mm)	091661	4	6	Blister	0.51	6.56	4.63	1.13	3.04	7.00	4.75	7.50	0.14	30
9167	CUP: Rubber Off-White - Round 1-3/4" (44mm)	091678	4	6	Blister	0.33	6.56	3.63	1.00	1.98	7.00	4.75	7.50	0.14	30
9168	CUP: Rubber Off-White - Square 3" (75mm)	091685	2	6	Blister	0.33	6.56	4.63	1.38	1.98	7.00	4.75	7.50	0.14	30
9174	CASTER: Cast-Iron Swivel Plate 2" (50mm)	091746	1	12	Blister	0.70	2.50	1.88	3	8.2	4.25	7.25	6.50	0.10	12

INDEX

Item Number	Description	UPC (039003)	Pcs. per Pk.	Pks./Ctn.	Package Type	Pkg. Wt (lb.)	Pkg. Height	Pkg. Width	Pkg. Depth	Carton Weight	Carton Height	Carton Width	Carton Depth	Carton	Cube (feet)	Catalog Page
9176	CASTER: Cast-Iron Swivel Plate 2-1/2" (64mm)	09176 0	1	6	Bulk	1.43	3.25	2.75	4.88	7.88	3.88	6.75	6.25	0.09	12	12
9180	CASTER: Cast-Iron Core Swivel Plate 6" x 2" (150 x 50mm) 1400 Series	09180 7	1	4	Bulk	8.00	-	-	-	-	-	-	-	-	-	12
9182	CASTER: Cast-Iron 2" (50mm) Rigid	09182 1	1	24	Bulk	0.51	2.50	1.50	2.75	12.14	6.5	7.50	10.50	0.30	12	12
9184	CASTER: Cast-Iron 2-1/2" (64mm) Rigid	09184 5	1	12	Bulk	1.19	3.25	2.25	4.5	14.26	6.5	7.50	10.50	0.30	12	12
9186	CASTER: Cast-Iron Core Swivel Plate 4" x 2" (100 x 50mm) 1400 Series	09186 9	1	4	Bulk	6.88	-	-	-	-	-	-	-	-	-	12
9187	CASTER: Cast-Iron Core Swivel Plate 8" x 2" (200 x 50mm) 1400 Series	09187 6	1	2	Bulk	11.5	-	-	-	-	-	-	-	-	-	12
9188	CASTER: Soft Rubber Bulk Medium-Duty 1-5/8" (40mm) Antique Copper Stem 02	09188 3	1	24	Bulk	0.32	2.25	1.50	2.25	7.68	6.00	4.00	10.50	0.15	6	6
9189	CASTER: Soft Rubber 3" (75mm) w/brake- Threaded Stem 3/8" x 1-1/2" (10mm x 38mm)	09189 0	1	12	Bulk	0.63	-	-	-	7.85	4.88	8.25	8.63	0.20	9	9
9190	CASTER: Soft Rubber 2" (50mm) w/brake- Threaded Stem 3/8" x 1-1/2" (10mm x 38mm)	09190 6	1	24	Bulk	0.39	4.1	2.56	2.16	9.92	5.9	7.87	7.87	0.211	9	9
9191	CASTER: Soft Rubber Friction Grip Ring Stem 87 2-1/2" (64mm)	09191 3	1	12	Bulk	0.42	4.00	1.00	2.75	5.00	6.00	4.00	10.50	0.15	9	9
9192	CASTER: Soft Rubber Friction Grip Ring Stem 88 2" (50mm)	09192 0	1	24	Bulk	0.41	4.50	1.50	2.50	9.84	6.50	7.50	10.50	0.30	9	9
9193	CASTER: Soft Rubber Friction Grip Ring 2" (50mm) Stem 7/16" x 1-3/8" (11 x 35mm)	09193 7	1	24	Bulk	0.46	4.00	1.50	2.50	11.00	5.50	7.63	8.25	0.30	9	9
9194	CASTER: Soft Rubber Threaded 2" (50mm) Stem 3/8" - 16 x 1-1/2" (10mm - 16 x 38mm)	09194 4	1	24	Bulk	0.75	4.00	1.50	2.50	18.07	6.50	7.50	10.50	0.30	9	9
9195	CASTER: Soft Rubber Threaded 3" (75mm) Stem 3/8" - 16 x 1-1/2" (10mm - 16 x 38mm)	09195 1	1	12	Bulk	1.55	5.00	1.50	3.00	18.63	6.50	7.50	10.50	0.30	9	9
9196	CASTER: Soft Rubber Threaded 4" (100mm) Stem 1/2" - 13 x 1-1/2" (10mm - 16 x 38mm)	09196 8	1	6	Bulk	2.25	6.50	2.88	4.00	13.52	6.50	7.50	10.50	0.30	9	9
9197	CASTER: Soft Rubber Friction Grip Ring 2-1/2" (64mm) Stem 7/16" x 1-7/8" (11 x 48mm)	09197 5	1	12	Bulk	0.43	4.75	1.13	3.00	5.17	6.00	4.00	10.50	0.15	9	9
9200	LEG TIP: Vinyl White - Round 5/8" (16mm)	09200 2	4	6	Blister	0.09	4.56	3.63	1.38	0.56	5.00	4.00	8.50	0.10	32	32
9201	LEG TIP: Vinyl White - Round 3/4" (19mm)	09201 9	4	6	Blister	0.10	4.56	3.63	1.38	0.62	5.00	4.00	8.50	0.10	32	32
9202	LEG TIP: Vinyl White - Round 7/8" (22mm)	09202 6	4	6	Blister	0.13	5.56	4.63	1.38	0.80	6.00	4.75	9.00	0.15	32	32
9203	LEG TIP: Vinyl White - Round 1" (25mm)	09203 3	4	6	Blister	0.15	5.56	4.63	1.38	0.92	6.00	4.75	9.00	0.15	32	32
9204	LEG TIP: Vinyl White - Round 1-1/8" (29mm)	09204 0	4	6	Blister	0.20	5.56	4.63	1.63	1.18	6.00	4.75	11.25	0.19	32	32
9205	LEG TIP: Vinyl White - Round 1/2" (13mm)	09205 7	4	6	Blister	0.07	4.56	2.63	1.38	0.44	5.25	3.00	5.75	0.05	32	32
9206	LEG TIP: Internal Plastic Black - 3/4" (19mm) Round	09206 4	4	6	Blister	0.07	4.56	2.63	0.88	0.42	5.00	3.00	6.50	0.08	34	34
9207	LEG TIP: Internal Plastic Black - 7/8" (22mm) Round	09207 1	4	6	Blister	0.07	4.56	2.63	0.88	0.42	5.00	3.00	6.50	0.08	34	34
9208	LEG TIP: Internal Plastic Black - 1" (25mm) Round	09208 8	4	6	Blister	0.08	4.56	2.63	1.38	0.48	5.00	3.00	8.50	0.10	34	34
9209	LEG TIP: Internal Plastic Black - 1-1/4" (32mm) Round	09209 5	4	6	Blister	0.09	4.56	2.63	1.38	0.54	5.00	3.00	8.50	0.10	34	34
9210	LEG TIP: Vinyl Black - 5/8" (16mm) Round	09210 1	4	6	Blister	0.09	4.56	3.63	1.38	0.56	5.00	4.00	8.50	0.10	32	32
9211	LEG TIP: Vinyl Black - 3/4" (19mm) Round	09211 8	4	6	Blister	0.10	4.56	3.63	1.38	0.62	5.00	4.00	8.50	0.10	32	32
9212	LEG TIP: Vinyl Black - 7/8" (22mm) Round	09212 5	4	6	Blister	0.14	5.56	4.63	1.38	0.82	6.00	4.75	9.00	0.15	32	32
9213	LEG TIP: Vinyl Black - 1" (25mm) Round	09213 2	4	6	Blister	0.16	5.56	4.63	1.38	0.96	6.00	4.75	9.00	0.15	32	32
9214	LEG TIP: Vinyl Black - 1-1/8" (29mm) Round	09214 9	4	6	Blister	0.20	5.56	4.63	1.63	1.18	6.00	4.75	11.25	0.19	32	32
9215	LEG TIP: Vinyl Black - 1/2" (13mm) Round	09215 6	4	6	Blister	0.07	4.56	2.63	1.38	0.42	5.25	3.00	5.75	0.05	32	32
9219	SLIDE GLIDE: Leg Tips 1" (25mm)	09219 4	4	6	Blister	0.18	5.500	4.625	1.000	1.09	7.00	5.25	8.00	0.17	24	24
9220	SLIDE GLIDE: Leg Tips 1-1/4" (32mm)	09220 0	4	6	Blister	0.20	5.50	4.63	1.25	1.20	8.00	5.00	7.50	0.17	24	24
9221	SLIDE GLIDE: Cup 1-3/4" (44mm)	09221 7	4	6	Blister	0.17	7.63	3.75	1.25	1.01	10.00	6.25	8.50	0.31	24	24
9222	SLIDE GLIDE: 2-3/4" (70mm) Cup	09222 4	4	4	Blister	0.25	9.25	4.63	1.25	1.50	10.00	6.00	8.50	0.30	24	24
9223	LEG TIP: Rubber Off-White - 1-1/4" (32mm) Round	09223 1	2	6	Blister	0.28	5.56	4.63	1.75	1.70	6.00	4.75	11.25	0.19	33	33
9224	LEG TIP: Rubber Black - 1-1/4" (32mm) Round	09224 8	2	6	Blister	0.28	5.56	4.63	1.75	1.70	6.00	4.75	11.25	0.19	33	33
9225	LEG TIP: Rubber Off-White - 1-1/2" (38mm) Round	09225 5	2	6	Blister	0.33	6.56	3.63	2.13	2.00	7.00	3.75	13.00	0.25	33	33
9226	LEG TIP: Rubber Black - 1-1/2" (38mm) Round	09226 2	2	6	Blister	0.33	6.56	3.63	2.13	2.00	7.00	3.75	13.00	0.25	33	33
9230	LEG TIP: Plastic Angle Black - 3/4" (19mm) Round	09230 9	4	6	Blister	0.06	4.56	2.63	1.38	0.34	5.25	3.00	8.50	0.08	34	34

Item Number	Description	UPC (039003)	Pcs. per Pk.	Pks./ Ctn.	Package Type	Pkg Wt. (lb.)	Pkg Height	Pkg Width	Pkg Depth	Carton Weight	Carton Height	Carton Width	Carton Depth	Carton	Cube (feet)	Catalog Page
9232	LEG TIP: Plastic Angle Black - 1" (25mm) Round	09232 3	4	6	Blister	0.09	4.56	3.63	1.38	0.56	5.00	4.00	8.50	0.10	0.10	34
9235	LEG TIP: Plastic Internal Black - 3/4" (19mm) Square	09235 4	4	6	Blister	0.06	4.56	2.63	1.06	0.34	5.25	6.00	8.50	0.15	0.15	34
9236	LEG TIP: Plastic Internal Black - 7/8" (22mm) Square	09236 1	4	6	Blister	0.07	4.56	2.63	1.38	0.42	5.00	3.00	8.50	0.10	0.10	34
9237	LEG TIP: Plastic Internal 1" (25mm) Black - Square / Plastic	09237 8	4	6	Blister	0.08	4.56	2.63	1.38	0.48	5.00	3.00	8.50	0.10	0.10	34
9238	LEG TIP: Plastic Internal Angle Black - 3/4" (19mm) Square	09238 5	4	6	Blister	0.07	4.56	2.63	1.38	0.42	5.25	3.00	8.50	0.08	0.08	34
9239	LEG TIP: Plastic Internal Angle Black - 7/8" (22mm) Square	09239 2	4	6	Blister	0.09	4.56	3.63	1.38	0.54	5.00	4.00	8.50	0.10	0.10	34
9240	SLIDE GUIDE: Square Pad w/ Screws & Adhesive 1" (25mm)	09240 8	8	6	Blister	0.15	5.50	4.63	0.38	0.91	7.75	5.25	2.75	0.06	0.06	24
9241	SLIDE GUIDE: Rectangle Pad 1" x 4" (25 x 100mm) w/ Adhesive	09241 5	4	6	Blister	0.16	7.63	3.75	0.50	0.93	8.00	5.25	3.75	0.09	0.09	24
9242	SLIDE GUIDE: Square Pad 1-3/8" (35mm) w/ Screws & Adhesive	09242 2	4	6	Blister	0.19	5.50	4.63	0.38	1.13	8.00	5.25	2.75	0.07	0.07	24
9243	SLIDE GUIDE: Triangle Pad 2" x 2" x 2-1/2" (50 x 50 x 64mm) w/ Screws & Adhesive	09243 9	4	6	Blister	0.14	5.50	4.63	0.38	0.86	8.00	5.25	2.75	0.07	0.07	24
9244	SLIDE GUIDE: Square Pad 2-1/8" (55mm) w/ Screws & Adhesive	09244 6	4	6	Blister	0.29	7.63	3.75	0.75	1.72	10.25	6.00	5.00	0.18	0.18	24
9245	CASTER: Polyamide Swivel Plate 5" (125mm)	09245 3	1	4	Blister	2.89	6.25	3.38	6.50	11.56	6.50	8.00	11.00	0.33	0.33	14
9246	CASTER: Polyamide Rigid 5" (125mm)	09246 0	1	4	Blister	2.30	6.25	3.38	5.00	9.18	6.50	8.00	11.00	0.33	0.33	14
9247	CASTER: Polyamide Swivel Plate w/Brake 5" (125mm)	09247 7	1	4	Blister	3.22	6.25	3.38	7.75	12.88	6.50	8.00	11.00	0.33	0.33	14
9248	SLIDE GUIDE: Round Pad 2-3/4" (70mm) w/ Screws & Adhesive	09248 4	4	6	Blister	0.34	7.63	4.63	0.75	2.06	10.00	6.00	4.75	0.16	0.16	24
9249	SLIDE GUIDE: Nail-On Pad 1-1/4" (32mm)	09249 1	4	6	Blister	0.12	5.50	4.63	1.00	0.73	8.00	5.00	7.50	0.17	0.17	24
9260	CASTER: Blue Elastic Rubber Swivel Plate 4" (100mm)	09260 6	1	5	Blister	0.95	5.25	3.13	5.13	4.75	5.75	8.00	9.63	0.26	0.26	10
9261	CASTER: Blue Elastic Rubber Rigid 4" (100mm)	09261 3	1	5	Blister	0.75	5.25	3.25	4.13	3.75	6.00	8.00	9.5	0.26	0.26	10
9262	CASTER: Blue Elastic Rubber Swivel Plate w/Brake 4" (100mm)	09262 0	1	5	Blister	1.10	5.13	3.13	6.75	5.50	6.00	8.00	12.00	0.33	0.33	10
9263	CASTER: Blue Elastic Rubber Swivel Plate 5" (125mm)	09263 7	1	4	Blister	1.13	6.00	3.00	6.00	4.50	6.50	8.00	11.00	0.33	0.33	10
9264	CASTER: Blue Elastic Rubber Rigid 5" (125mm)	09264 4	1	4	Blister	0.94	6.13	3.25	4.13	3.75	6.50	8.00	11.00	0.33	0.33	10
9265	CASTER: Blue Elastic Rubber Swivel Plate w/Brake 5" (125mm)	09265 1	1	4	Blister	1.25	6.13	3.13	6.75	5.00	6.50	8.00	11.00	0.33	0.33	10
9266	SNOWMOBILE: Lift Elevates Snowmobile 28" and Folds Down for Storage. Available only in Canada.	09266 8	1	1	Carton	68.00	5.12	23.23	57.87	—	—	—	—	—	3.98	NA
9270	CASTER: Hard Rubber 2" (50mm) Swivel Plate	09270 5	1	50	Blister	0.43	2.50	1.88	3.00	21.42	5.50	11.75	9.50	0.36	0.36	11
9271	CASTER: Hard Rubber 2" (50mm) Swivel Plate w/Brake	09271 2	1	50	Blister	0.48	2.50	2.00	3.25	24.08	5.50	11.75	9.50	0.36	0.36	11
9272	CASTER: Hard Rubber 2" (50mm) Rigid	09272 9	1	50	Blister	0.31	2.25	1.50	2.88	15.48	5.50	11.75	9.50	0.36	0.36	11
9273	CASTER: Hard Rubber 2-1/2" (64mm) Swivel Plate	09273 6	1	30	Blister	0.96	3.13	2.75	3.88	28.92	8.00	11.75	9.50	0.52	0.52	11
9274	CASTER: Hard Rubber 2-1/2" (64mm) Swivel Plate w/Brake	09274 3	1	30	Blister	1.05	3.00	2.88	4.25	31.46	8.00	11.75	9.50	0.52	0.52	11
9275	CASTER: Hard Rubber 2-1/2" (64mm) Rigid	09275 0	1	30	Blister	0.76	3.00	2.13	4.50	22.8	8.00	11.75	9.50	0.52	0.52	11
9276	CASTER: Hard Rubber 3" (75mm) Swivel Plate	09276 7	1	20	Blister	1.13	3.75	3.13	4.75	22.56	8.00	11.75	9.50	0.52	0.52	11
9277	CASTER: Hard Rubber 3" (75mm) Swivel Plate w/Brake	09277 4	1	20	Blister	1.47	3.75	3.13	4.63	29.46	8.00	11.75	9.50	0.52	0.52	11
9278	CASTER: Hard Rubber 3" (75mm) Rigid	09278 1	1	20	Blister	1.13	3.50	2.25	4.88	22.54	8.00	11.75	9.50	0.52	0.52	11
9279	CASTER: Hard Rubber 4" (100mm) Swivel Plate	09279 8	1	10	Blister	2.65	4.50	4.00	5.63	26.46	9.00	11.75	9.50	0.58	0.58	11
9280	CASTER: Hard Rubber 4" (100mm) Swivel Plate w/Brake	09280 4	1	10	Blister	2.78	4.50	4.00	5.63	27.78	9.00	11.75	9.50	0.58	0.58	11
9281	CASTER: Hard Rubber 4" (100mm) Rigid	09281 1	1	10	Blister	2.29	4.75	3.00	6.25	22.94	9.00	11.75	9.50	0.58	0.58	11
9285	CASTER: Semi Elastic Rubber 3" (75mm) Swivel Plate	09285 9	1	5	Blister	0.78	4.50	3.13	5.13	8.50	5.25	8.00	10.50	0.26	0.26	10
9286	CASTER: Semi Elastic Rubber 3" (75mm) Rigid	09286 6	1	10	Blister	0.50	4.13	3.38	4.50	5.00	6.50	8.00	14.00	0.42	0.42	10
9287	CASTER: Semi Elastic Rubber 3" (75mm) Swivel Plate w/Brake	09287 3	1	5	Blister	0.85	4.50	3.13	6.25	9.44	5.25	8.00	10.50	0.26	0.26	10
9288	CASTER: Semi Elastic Rubber 4" (100mm) Swivel Plate	09288 0	1	5	Blister	0.95	5.00	3.13	5.25	4.75	5.50	7.50	9.50	0.23	0.23	10
9289	CASTER: Semi Elastic Rubber 4" (100mm) Rigid	09289 7	1	5	Blister	0.75	5.13	3.38	4.13	3.75	5.50	8.00	9.50	0.24	0.24	10
9290	CASTER: Semi Elastic Rubber 4" (100mm) Swivel Plate w/Brake	09290 3	1	5	Blister	1.05	5.13	3.13	6.25	5.25	6.00	8.00	12.00	0.33	0.33	10

INDEX

Item Number	Description	UPC (039003)	Pcs. per Pk.	Pks./Ctn.	Package Type	Pkg. Wt. (lb.)	Pkg. Height	Pkg. Width	Pkg. Depth	Carton Weight	Carton Height	Carton Width	Carton Depth	Carton	Cube (feet)	Catalog Page
9298	SNOWMOBILE: Three Piece Dolly Set Permits Snowmobile to Turn in Minimal Space	09298 9	3	2	Tie Label	11.85	-	-	-	24.00	11.75	8.50	15.00	0.88	18	
9299	TRI-DOLLY: 6" (150mm)	09299 6	1	6	Label	0.84	6.00	6.00	2.00	5.02	6.50	7.50	10.50	0.30	18	
9314	SLIDE GLIDE+: 5" (125mm) Furniture Slide w/Fleece Socks	09314 6	8	4	Blister Sleeve	0.52	13.00	6.00	2.00	2.54	6.30	8.46	14.57	0.45	25	
9316	SLIDE GLIDE: 4" (100mm) Furniture Slide	09316 0	4	4	Blister Sleeve	0.52	7.63	4.63	2.00	2.25	8.13	5.00	6.63	0.15	25	
9319	CASTER: Metal Ball Soft Tread Brass 2-1/4" (57mm) Plate 01	09319 1	2	6	Blister	0.95	5.88	4.25	2.50	5.68	6.25	4.75	13.25	0.23	3	
9320	CASTER: Metal Ball Soft Tread Brass 2-1/4" (57mm) Stem 02	09320 7	2	6	Blister	0.89	5.88	4.25	2.50	5.34	6.25	4.75	13.25	0.23	3	
9335	SLIDE GLIDE: Mover Pad 3" x 3" (75mm) Black Square	09335 1	4	6	Blister	0.53	9.75	7.25	1.63	3.18	7.25	4.50	14.50	0.27	24	
9336	SLIDE GLIDE: Mover Pad 3" x 3" (75mm) Almond Square	09336 8	4	6	Blister	0.34	9.75	7.25	1.63	2.42	10.13	5.63	15.00	0.50	24	
9337	SLIDE GLIDE: Mover Pad 3" x 3" (75mm) White Square	09337 5	4	6	Blister	0.53	9.75	7.25	1.63	3.18	7.25	4.75	14.75	0.29	24	
9338	SLIDE GLIDE: Mover Pad 5-3/4" x 8-1/4" (150 x 208mm) Tan Pad	09338 2	4	3	Blister	0.75	9.25	9.88	2.00	2.63	9.50	10.25	7.00	0.39	24	
9344	CASTER: Soft Rubber 2" (50mm) Threaded Stem 07 Medium-Duty	09344 3	2	6	Blister	0.80	6.56	4.63	2.00	4.82	7.00	4.75	13.00	0.25	7	
9345	CASTER: Soft Rubber 2" (50mm) Stem 02 Medium-Duty	09345 0	2	6	Blister	0.87	6.56	4.63	2.00	5.24	7.00	4.75	13.00	0.25	6	
9346	CASTER: Soft Rubber 2" (50mm) Plate 13 Medium-Duty	09346 7	2	6	Blister	0.89	6.56	4.63	2.00	5.34	7.00	4.75	13.00	0.25	6	
9347	CASTER: Soft Rubber 1-5/8" (40mm) Stem 02 Medium-Duty	09347 4	2	6	Blister	0.71	6.56	4.63	1.63	4.24	7.00	4.75	11.00	0.21	6	
9348	CASTER: Soft Rubber 1-5/8" (40mm) Plate 13 Medium-Duty	09348 1	2	6	Blister	0.74	6.56	4.63	1.50	4.42	7.00	4.75	11.00	0.21	6	
9352	CASTER: Hooded Ball 1-5/8" (40mm) Stem 02 Brass	09352 8	2	6	Blister	0.68	6.56	4.63	2.00	4.08	7.00	4.75	13.00	0.25	3	
9353	CASTER: Hooded Ball 1-5/8" (40mm) Plate Brass Plate 13	09353 5	2	6	Blister	0.73	6.56	4.63	2.00	4.36	7.00	4.75	13.00	0.25	3	
9354	CASTER: Hooded Ball 2" (50mm) Stem 02 Brass	09354 2	2	6	Blister	0.87	6.56	4.63	2.25	5.20	7.00	4.75	13.00	0.25	3	
9355	CASTER: Hooded Ball 2" (50mm) Plate Brass Plate 18	09355 9	2	6	Blister	0.90	6.56	4.63	2.00	5.40	7.00	4.75	13.00	0.25	3	
9358	CASTER: Hooded Ball 2" (50mm) Stem 02 Chrome	09358 0	2	6	Blister	0.86	6.56	4.63	2.00	5.18	7.00	4.75	13.00	0.25	3	
9359	CASTER: Hooded Ball 2" (50mm) Chrome Plate 18	09359 7	2	6	Blister	0.90	6.56	4.63	2.00	5.38	7.00	4.75	13.00	0.25	3	
9360	CASTER: Hooded Ball 2" (50mm) Stem 82 Chrome	09360 3	2	6	Blister	0.86	6.56	4.63	2.00	5.18	7.00	4.75	13.00	0.25	3	
9361	CUP: Dark Woodgrain Effect w/FELT base 1-3/4" (44mm) - Round	09361 0	4	6	Blister	0.22	8.50	4.38	1.75	1.32	8.75	4.75	10.00	0.24	30	
9362	CUP: Dark Woodgrain Effect w/FELT base 2-3/8" (60mm) - Round	09362 7	4	6	Blister	0.28	8.50	4.38	1.75	1.66	8.75	4.75	10.00	0.24	30	
9363	CUP: Light Woodgrain Effect w/FELT base 1-3/4" (44mm) - Round	09363 4	4	6	Blister	0.22	8.50	4.38	1.75	1.32	8.75	4.75	10.00	0.24	30	
9364	CUP: Light Woodgrain Effect w/FELT base 2-3/8" (60mm) - Round	09364 1	4	4	Blister	0.28	8.50	4.38	1.75	1.66	8.75	4.75	10.00	0.24	30	
9369	FELTGARD: Mover Pad 3" x 3" (75 x 75mm) Pad Tan	09369 6	4	6	Blister	0.45	9.75	7.25	1.63	3.06	9.75	7.50	11.50	0.49	21	
9388	CASTER: Polypropylene 5" x 2" (125 X 50mm) Swivel Series 1400	09388 7	1	4	Blister	4.88	6.25	4.00	6.00	19.52	9.75	12.00	10.00	0.68	NA	
9389	CASTER: Polypropylene 5" x 2" (125 X 50mm) Rigid Series 1400	09389 4	1	4	Blister	4.00	6.25	4.00	4.50	16.00	7.75	9.00	11.63	0.44	NA	
9392	CASTER: Polypropylene 2" (50mm) Swivel Plate	09392 4	1	36	Blister	0.36	2.50	1.88	3.00	13.00	6.50	7.50	10.50	0.30	13	
9393	CASTER: Polypropylene 2-1/2" (64mm) Swivel Plate	09393 1	1	12	Blister	0.83	3.00	2.75	4.00	10.00	6.50	7.50	10.50	0.30	13	
9394	CASTER: Polypropylene 3" (75mm) Swivel Plate	09394 8	1	8	Blister	1.25	3.75	3.13	4.75	10.02	6.50	7.50	10.50	0.30	13	
9395	CASTER: Polypropylene 4" (100mm) Swivel Plate	09395 5	1	4	Blister	1.45	4.63	3.50	5.00	5.80	6.50	7.50	10.50	0.30	13	
9396	CASTER: Polypropylene 2" (50mm) Rigid	09396 2	1	24	Blister	0.24	2.50	1.50	2.75	5.60	4.25	8.00	7.88	0.15	13	
9397	CASTER: Polypropylene 2-1/2" (64mm) Rigid	09397 9	1	6	Blister	0.61	3.13	2.25	4.50	3.47	3.50	8.00	7.13	0.12	13	
9398	CASTER: Polypropylene 3" (75mm) Rigid	09398 6	1	6	Blister	0.71	3.75	2.50	4.88	5.09	4.50	8.00	8.00	0.17	13	
9399	CASTER: Polypropylene 4" (100mm) Rigid	09399 3	1	4	Blister	1.14	4.75	2.50	5.00	4.54	6.50	7.50	10.50	0.30	13	
9401	CASTER: Twin Wheel 1-5/8" (40mm) Plate 01 - Black	09401 3	2	6	Blister	0.40	6.56	4.63	2.13	2.42	7.00	4.75	13.00	0.25	4	
9402	CASTER: Twin Wheel 1-5/8" (40mm) Stem 02 - Black	09402 0	2	6	Blister	0.39	6.56	4.63	2.13	2.34	7.00	4.75	13.00	0.25	4	
9403	CASTER: Twin Wheel 2" (50mm) Plate 01 - Black / Soft Tread	09403 7	2	6	Blister	0.52	6.56	4.63	2.13	3.10	7.00	4.75	13.00	0.25	4	
9404	CASTER: Twin Wheel 2" (50mm) Stem 02 - Black / Soft Tread	09404 4	2	6	Blister	0.48	6.56	4.63	2.13	2.90	7.00	4.75	13.00	0.25	4	

Item Number	Description	UPC (039003)	Pcs. per Pk.	Pks./ Ctn.	Package Type	Pkg Wt. (lb.)	Pkg Height	Pkg Width	Pkg Depth	Carton Weight	Carton Height	Carton Width	Carton Depth	Carton Cube (feet)	Catalog Page
9405	CASTER: Twin Wheel 2" (50mm) Plate 01 - Black w/Brake	09405 1	2	6	Blister	0.57	6.56	4.63	2.13	3.44	7.00	4.75	13.00	0.25	4
9406	CASTER: Twin Wheel 2" (50mm) Stem 02 - Black w/Brake	09406 8	2	6	Blister	0.55	6.56	4.63	2.13	3.30	7.00	4.75	13.00	0.25	4
9407	FELT GARD: 3-1/2" (89mm) Round Pads Felt w/ thick 1/2" Black EVA foam	09407 5	4	4	Blister	0.15	9.25	4.63	1.25	1.20	9.25	6.25	5.25	0.19	21
9408	FELT: 2-1/2" Felt Sliders (Felt w/ thick 1/2" Black EVA foam) 4 pcs per pack.	09408 2	4	4	Blister	0.11	8.00	4.50	1.25	0.75	8.00	6.25	5.25	0.15	21
9417	CASTER: Twin Wheel 2" (50mm) Plate 01 - Black	09417 4	2	6	Blister	0.52	6.56	4.63	2.13	3.10	7.00	4.75	13.00	0.25	4
9418	CASTER: Twin Wheel 2" (50mm) Stem 02 - Black	09418 1	2	6	Blister	0.48	6.56	4.63	2.13	2.90	7.00	4.75	13.00	0.25	4
9419	CASTER: Twin Wheel 2" (50mm) Stem 82 - Black	09419 8	2	6	Blister	0.48	6.56	4.63	2.13	2.90	7.00	4.75	13.00	0.25	4
9420	CASTER: Twin Wheel 1-5/8" (40mm) U-Bracket - Black	09420 4	2	6	Blister	0.50	6.56	4.63	2.13	3.00	7.00	4.75	13.00	0.25	4
9421	SURFACE GARD: Felt Light-duty 3/8" (10mm) Green Pads	09421 1	28	12	Blister	0.01	4.56	3.63	0.13	0.17	5.00	3.38	2.00	0.02	28
9422	CASTER: Polyurethane Red on Black Polypropylene 6" x 2" - Swivel	09422 8	1	4	Blister	5.64	-	-	-	21.15	9.50	10.00	11.75	0.65	12
9423	SURFACE GARD: Felt Light-duty Assorted Green Pads	09423 5	46	12	Blister	0.05	7.88	3.50	0.39	0.68	8.47	3.74	3.74	0.07	28
9424	CASTER: Polyurethane Red on Black Polypropylene 6" x 2" - Rigid	09424 2	1	4	Blister	4.54	-	-	-	18.00	8.50	8.25	12.63	0.51	12
9425	SURFACE GARD FELT Light-duty Assorted Brown Pads	09425 9	46	12	Blister	0.05	7.88	3.50	0.39	0.68	8.47	3.74	3.74	0.07	28
9427	SURFACE GARD: FELT 4-1/4" x 6" (108 x 150mm) Sheets - Green	09427 3	2	12	Blister	0.11	8.75	5.63	0.50	1.42	9.25	5.75	6.25	0.19	28
9428	CASTER: Twin Wheel 2-1/2" (64mm) Stem 88 - Black / Soft Tread	09428 0	1	4	Blister	0.41	6.56	4.63	1.75	2.44	7.00	4.75	13.00	0.25	4
9431	FELTGARD: Mover Pad 5-3/4" x 8-1/4" (146 x 208mm) Tan Pad	09431 0	4	6	Blister	1.15	9.38	10.00	3.00	6.97	9.50	10.50	19.25	1.11	21
9433	SURFACE GARD: Felt Light-duty 6" x 18" (15 x 46cm) Green Blanket	09433 4	1	12	Blister	0.11	7.13	5.00	0.50	1.32	7.50	5.25	3.25	0.07	28
9435	SHIM: Plastic White	09435 8	6	6	Blister	0.09	4.56	3.63	1.38	0.54	5.00	4.00	8.50	0.10	37
9436	SHIM: Plastic White / Display Jar (300pcs)	09436 5	300	6	Display Jar	2.68	8.75	5.50	5.50	2.68	-	-	-	1.16	37
9438	POWER PANEL: SLIDE GLIDE	-	144	1	Power Panel	15.00	-	-	-	20.15	51.00	15.00	7.00	3.10	40
9439	SOCKET: Metal 3/8" (10mm)	09439 6	4	6	Blister	0.09	4.56	2.63	0.88	0.54	5.00	3.00	6.50	0.08	5
9440	SOCKET: Plastic Bed Frame 3/8" (10mm)	09440 2	4	6	Blister	0.07	4.56	2.63	1.38	0.44	5.00	3.00	8.50	0.10	5
9441	CASTER: Appliance White Dual Wheels 7/8" (22mm) - Threaded Stem	09441 9	4	6	Clamshell	1.21	7.63	4.88	2.38	7.28	8.00	5.25	15.75	0.38	5
9442	TRI-DOLLY: 12" (300mm)	09442 6	1	6	Label	2.47	2.50	12.00	12.00	14.8	11.5	13.00	16.25	1.41	18
9444	GLIDE: Phenolic 1-1/4" (32mm) Threaded Stem 5/16" - 18 x 1-1/2" (8mm - 18 x 38mm)	09444 0	4	6	Blister	0.25	4.56	2.63	1.38	1.48	5.00	3.00	11.5	0.13	26
9445	GLIDE: Plastic Cushion Nail-On 5/8" (16mm)	09445 7	4	6	Blister	0.05	4.56	2.63	1.06	0.28	5.25	3.00	5.75	0.05	26
9446	GLIDE: Plastic Cushion Nail-On 3/4" (19mm)	09446 4	4	6	Blister	0.06	4.56	2.63	1.38	0.36	5.25	3.00	8.50	0.08	26
9447	GLIDE: Plastic Cushion Nail-On 7/8" (22mm)	09447 1	4	6	Blister	0.07	4.56	2.63	1.38	0.40	5.25	3.00	8.50	0.08	26
9448	GLIDE: Plastic Cushion Nail-On 1-1/8" (29mm)	09448 8	4	6	Blister	0.10	4.56	2.63	1.38	0.60	5.00	4.00	8.50	0.10	26
9449	GLIDE: Metal Cushion 7/8" (22mm) Threaded Stem 1/4" - 20 x 1/2" (6mm - 20 x 13mm)	09449 5	4	6	Blister	0.12	4.56	2.63	1.38	0.74	5.25	3.00	8.50	0.08	26
9450	GLIDE: Metal Cushion 1-1/16" (27mm) Threaded Stem 1/4" - 20 x 1/2" (6mm - 20 x 13mm)	09450 1	4	6	Blister	0.18	4.56	3.63	1.38	1.06	5.00	4.00	8.50	0.10	26
9451	GLIDE: Metal Cushion 1-1/4" (32mm) Threaded Stem 1/4" - 20 x 1/2" (6mm - 20 x 13mm)	09451 8	4	6	Blister	0.20	4.56	3.63	1.38	1.20	5.00	4.00	8.50	0.10	26
9452	SLIDE GLIDE: Round Pad 1" (25mm) w/ Screws & Adhesive	09452 5	8	6	Blister	0.21	5.50	4.63	0.38	1.24	7.00	3.25	4.50	0.06	24
9453	SLIDE GLIDE: Round Pad 2" (50mm) w/ Screws & Adhesive	09453 2	4	6	Blister	0.24	5.50	4.63	0.75	1.42	7.00	5.25	5.25	0.11	24
9454	SLIDE GLIDE: Round Pad 2-1/2" (64mm) w/ Screws & Adhesive	09454 9	4	6	Blister	0.33	7.63	3.75	0.63	1.98	7.00	6.25	4.75	0.12	24
9455	SLIDE GLIDE: Round Pad 1-1/2" (38mm) w/ Screws & Adhesive	09455 6	4	6	Blister	0.18	5.50	4.63	0.38	1.10	7.25	4.50	5.25	0.10	24
9456	SLIDE GLIDE: Round Pad 7/8" (22mm) w/ Screws & Adhesive	09456 3	8	6	Blister	0.19	5.50	4.63	0.38	1.16	5.00	4.00	6.50	0.08	24
9457	SLIDE GLIDE: Strips 5/8" x 3" (16 x 75mm)	09457 0	4	6	Blister	0.10	5.50	4.63	0.38	0.93	5.00	5.75	2.90	0.05	24
9468	SLIDE GLIDE: Hex Based Appliance 1-1/2" (38mm) w/ Threaded Stem	09468 6	4	4	Blister	0.55	7.63	3.75	1.63	1.85	7.88	4.00	7.13	0.13	24
9468S	SLIDE GLIDE: Hex Based Appliance 1-1/2" (38mm) w/ Threaded Stem / Clip Strip	99468 9	4	6	Blister	0.55	7.63	3.75	1.63	3.30	8.25	4.75	11.50	0.26	24, 40
9469	SLIDE GLIDE: Nail-On Pad 7/8" (22mm)	09469 3	8	6	Blister	0.09	5.50	4.63	1.00	0.52	5.00	4.00	6.50	0.08	24

INDEX

Item Number	Description	UPC (039003)	Pcs. per Pk.	Pks./Ctn.	Package Type	Pkg. Wt (lb.)	Pkg. Height	Pkg. Width	Pkg. Depth	Carton Weight	Carton Height	Carton Width	Carton Depth	Cube (feet)	Catalog Page
9471	SLIDE GLIDE: Dinette Pack	99471 9	20		Blister	0.45	7.63	4.63	0.75	5.35	8.50	5.00	12.00	0.30	24
9471 S	SLIDE GLIDE: Dinette Pack / Clip Strip	99471 9	20	6	Blister	0.45	7.63	4.63	0.75	5.35	8.50	5.00	12.00	0.30	40
9477	CASTER: Soft Rubber 2" (50mm) Swivel Plate	09477 8	1	30	Blister	0.46	2.38	1.88	3.00	12.00	5.25	8.00	10.50	0.26	8
9478	CASTER: Soft Rubber 2-1/2" (64mm) Swivel Plate	09478 5	1	10	Blister	1.01	3.25	2.75	4.00	9.46	6.00	8.00	8.00	0.22	8
9479	CASTER: Soft Rubber 3" (75mm) Swivel Plate	09479 2	1	10	Blister	1.38	3.75	3.13	4.75	13.00	6.00	8.00	10.25	0.28	8
9480	CASTER: Soft Rubber 4" (100mm) Swivel Plate	09480 8	1	5	Blister	2.60	4.50	4.13	5.75	13.00	5.50	8.00	13.50	0.34	8
9481	CASTER: Soft Rubber 2" (50mm) Rigid	09481 5	1	16	Blister	0.33	2.38	1.50	2.63	5.38	4.75	8.00	5.50	0.12	8
9482	CASTER: Soft Rubber 2-1/2" (64mm) Rigid	09482 2	1	8	Blister	0.74	3.00	2.13	4.38	6.00	4.75	8.00	7.00	0.15	8
9483	CASTER: Soft Rubber 3" (75mm) Rigid	09483 9	1	8	Blister	1.18	3.75	2.25	4.88	9.22	5.00	8.00	8.25	0.19	8
9484	CASTER: Soft Rubber 4" (100mm) Rigid	09484 6	1	5	Blister	2.30	5.00	3.00	6.13	11.00	6.00	8.00	12.75	0.35	8
9485	WonderLevel: Table Leveler 1" (25mm) includes FeltCard®, Slide Glide®, Inserts & Hex Wrench	09485 3	17	6	Blister	0.34	8.63	4.75	1.38	2.29	8.75	4.88	8.38	0.21	27
9487	CASTER: Soft Rubber 1-1/4" (32mm) Swivel Plate	09487 7	1	50	Blister	0.14	1.63	1.25	1.75	6.80	5.25	5.75	6.50	0.12	8
9488	CASTER: Soft Rubber 1-1/4" (32mm) Rigid	09488 4	1	50	Blister	0.11	1.50	0.75	1.50	5.20	5.25	5.75	6.50	0.12	8
9489	CASTER: Soft Rubber 1-1/2" (38mm) Swivel Plate	09489 1	1	30	Blister	0.20	2.00	1.50	2.50	9.90	5.88	6.25	7.75	0.18	8
9490	CASTER: Soft Rubber 1-1/2" (38mm) Rigid	09490 7	1	12	Blister	0.17	2.00	1.00	1.88	1.89	3.88	6.00	2.75	0.18	8
9491	CASTER: Soft Rubber 6" (150mm) Swivel Plate	09491 4	1	4	Blister	3.40	7.00	2.38	6.50	13.60	9.75	12.00	10.00	0.68	8
9492	CASTER: Soft Rubber 6" (150mm) Rigid	09492 1	1	4	Blister	2.58	7.00	2.38	6.00	10.30	9.75	12.00	10.00	0.68	8
9493	CASTER: Mold-On Rubber 6" x 2" (150 x 50mm) Swivel Plate / 1400 series	09493 8	1	4	Blister	8.00	7.50	4.00	6.50	32.00	7.50	15.00	10.00	0.65	11
9494	CASTER: Mold-On Rubber 6" x 2" (150 x 50mm) Rigid / 1400 series	09494 5	1	4	Blister	7.00	7.50	4.00	5.75	28.00	7.50	15.00	10.00	0.65	11
9496	CASTER: Soft Rubber 3" (75mm) w/Brake Threaded Stem 3/8" - 16 x 1-1/2" (10mm - 16 x 38mm)	09496 9	1	4	Blister	1.70	7.75	5.63	3.13	6.15	8.00	6.00	13.38	0.37	8
9498	DOOR STOP: Spring, Nickel	09498 3	2	6	Blister	0.19	4.56	2.63	1.00	1.16	7.00	3.00	7.50	0.14	31
9500	DOOR STOP: Spring Brass	09500 3	2	6	Blister	0.19	4.56	2.63	1.00	1.16	7.00	4.75	7.50	0.14	31
9508	CASTER: Soft Rubber 6" (150mm) Swivel Plate w/Brake	09508 9	1	4	Blister	3.58	7.00	2.38	5.75	14.31	9.75	12.00	10.00	0.68	8
9509	CASTER: Soft Rubber 2" (50mm) Swivel Plate w/Brake	09509 6	1	20	Blister	0.50	2.50	1.88	3.00	14.50	5.75	8.00	9.50	0.25	8
9510	CASTER: Soft Rubber 2-1/2" (64mm) Swivel Plate w/Brake	09510 2	1	10	Blister	1.09	3.00	2.75	4.00	10.19	6.00	8.00	8.75	0.24	8
9511	CASTER: Soft Rubber 3" (75mm) Swivel Plate w/Brake	09511 9	1	10	Blister	1.49	3.63	3.13	4.75	14.32	7.50	8.00	10.25	0.36	8
9512	CASTER: Soft Rubber 4" (100mm) Swivel Plate w/Brake	09512 6	1	5	Blister	2.97	4.88	4.00	6.00	13.5	5.50	8.25	13.5	0.35	8
9513	GLIDE: Plastic 1-1/2" (38mm) Cushion Nail-On	09513 3	4	6	Blister	0.11	4.56	3.63	1.38	0.68	5.00	4.00	8.50	0.10	26
9516	CASTER: Hooded Ball Bulk 2" (50mm) Stem 02 Brass	09516 4	1	12	Bulk	0.40	2.38	2.13	2.50	5.00	5.00	8.00	6.00	0.14	3
9517	CASTER: Hooded Ball Bulk 2" (50mm) Plate Brass Plate 18	09517 1	1	12	Bulk	0.42	2.50	2.13	3.00	5.00	5.00	8.00	6.00	0.14	3
9518	CASTER: Bed Frame 2-1/8" (54mm) Stem - Black Soft Tread w/Brake	09518 8	2	6	Clamshell	0.92	7.25	5.75	2.13	5.54	7.00	6.75	12.00	0.33	5
9522	BED LEGS: 6" (150mm) Continental Wood Replacement Bed Legs.	09522 5	6	4	Poly bag w/ Header	1.79	10.50	4.88	3.00	15.43	7.50	12.63	5.00	0.27	36
9532	CASTER: Bed Frame Adjustable 2-1/8" (54mm) Stem - Black Soft Tread	09532 4	2	4	Blister	2.00	9.75	7.25	2.50	14.33	9.50	10.20	12.40	0.70	5
9535	CASTER: Bed Frame 2-1/8" (54mm) Stem - White	09535 5	2	6	Clamshell	0.94	7.25	5.75	2.13	5.64	7.00	6.75	12.00	0.33	5
9536	CASTER: Bed Frame 2-1/8" (54mm) Stem - White w/Brake	09536 2	2	6	Clamshell	1.06	7.38	5.75	2.00	6.36	7.00	6.75	12.00	0.33	5
9537	BED RISER: 6-1/8" (155mm) Molded Riser Adds Storage Space Beneath Beds Almond	09537 9	4	6	Carton	3.00	11.50	6.63	7.00	19.00	11.50	21.50	14.00	2.00	36
9541	CASTER: Polypropylene 2" (50mm) Swivel Plate w/Brake	09541 6	1	30	Bulk	0.38	11.75	9.88	0.25	11.49	5.88	8.00	9.75	0.27	13
9543	CASTER: Polypropylene 3" (75mm) Swivel Plate w/Brake	09543 0	1	20	Bulk	1.26	7.50	5.63	0.25	25.20	7.88	8.00	14.75	0.54	13
9546	LAZY SUSAN: 3" (75mm)	09546 1	1	10	Poly bag	0.22	7.50	5.63	0.25	2.24	4.00	6.00	5.25	0.07	36
9547	LAZY SUSAN: 4" (100mm)	09547 8	1	10	Poly bag	0.34	7.50	5.63	0.25	3.42	4.00	6.00	5.25	0.07	36
9548	LAZY SUSAN: 6" (150mm)	09548 5	1	5	Poly bag	0.64	9.25	7.25	0.25	6.38	4.00	7.50	7.50	0.13	36

Item Number	Description	UPC (039003)	Pcs. per Pk.	Pks./ Ctn.	Package Type	Pkg Wt. (lb.)	Pkg Height	Pkg Width	Pkg Depth	Carton Weight	Carton Height	Carton Width	Carton Depth	Carton	Cube (feet)	Catalog Page
9549	LAZY SUSAN: 12" (300mm)	09549 2	1	5	Poly bag	1.73	15.25	13.5	0.25	17.30	4.00	14.00	13.00	0.42	36	
9551	DOOR KNOB / WALL PROTECTOR: 3-1/4" (83mm) w/textured surface	09551 5	1	6	Blister	0.08	8.38	4.81	0.25	0.55	8.50	5.00	2.25	0.06	37	
9551S	DOOR KNOB / WALL PROTECTOR: 3-1/4" (83mm) w/textured surface	09551 5	1	12	Blister	0.08	8.38	4.81	0.25	0.55	8.50	5.00	2.25	0.06	37	
9552	DOOR KNOB / WALL PROTECTOR: 5" (125mm) w/textured surface	09552 2	1	6	Blister	0.17	10.38	5.81	0.25	1.14	10.75	6.00	2.25	0.09	37	
9552S	DOOR KNOB / WALL PROTECTOR: 5" (125mm) w/textured surface	09552 2	1	12	Blister	0.17	10.38	5.81	0.25	1.14	10.75	6.00	2.25	0.09	37	
9556	CASTER: Light-duty 1-1/4" (32mm) Plastic Wheel Black - Plate 1-3/16" x 1-3/4" (30 x 44mm)	09556 0	4	6	Blister	0.42	6.56	4.63	1.25	2.54	7.00	4.75	11.00	0.21	6	
9557	CASTER: Light-duty 1-1/4" (32mm) Plastic Wheel Black - Stem 02	09557 7	4	6	Blister	0.44	6.56	4.63	1.25	2.66	7.00	4.75	11.00	0.21	6	
9558	CASTER: Light-duty 1-5/8" (40mm) Plastic Wheel Black - Plate 1-3/16" x 1-3/4" (30 x 44mm)	09558 4	4	6	Blister	0.56	6.56	4.63	1.50	3.38	7.00	4.75	11.00	0.21	6	
9559	CASTER: Light-duty 1-5/8" (40mm) Plastic Wheel Black - Stem 02	09559 1	4	6	Blister	0.58	6.56	4.63	1.50	3.50	7.00	4.75	11.00	0.21	6	
9566	DOOR STOP: Cushion Ivory	09566 9	2	6	Blister	0.23	6.63	4.63	1.00	1.40	7.00	4.75	7.50	0.14	31	
9568	DOOR STOP: Cushion White	09568 3	2	6	Blister	0.24	6.63	4.63	1.00	1.42	7.00	4.75	7.50	0.14	31	
9573	DOOR STOP: Cushion clear	09573 7	1	6	Blister	0.06	4.56	2.63	0.88	0.36	5.25	3.00	5.75	0.05	31	
9581	DISPLAY MERCHANTISER: Triangular Wire Rack Assortment	-	-	-	-	-	-	-	-	-	-	-	-	-	-	40
9582	DISPLAY MERCHANTISER: Triangular Wire Rack Assortment	-	-	-	-	-	-	-	-	-	-	-	-	-	-	40
9583	DISPLAY MERCHANTISER: Triangular Wire Rack Assortment	-	-	-	-	-	-	-	-	-	-	-	-	-	-	40
9584	REPLACEMENT WHEEL: Semi-Pneumatic Metal Hub Ribbed Tread 12" x 1-3/4" (300 x 44mm) - 1/2" (13mm) bore	09584 3	1	6	Wheel Tag	5.07	12.00	1.75	-	29.50	12.05	12.05	13.23	1.11	16	
9588	REPLACEMENT WHEEL: 10" x 2-1/2" (250 x 64mm) Offset Ribbed Tread - 5/8" (16mm) bore	09588 1	1	6	Wheel Tag	5.33	10.00	2.50	-	32.00	10.50	11.00	15.25	1.02	16	
9589	REPLACEMENT WHEEL: Semi-Pneumatic Metal Hub Diamond Tread 6" x 1-1/2" (150 x 38mm) - 1/2" (13mm) bore	09589 8	1	12	Wheel Tag	1.20	6.00	1.50	-	14.79	6.30	9.45	12.20	0.42	16	
9590	REPLACEMENT WHEEL: Semi-Pneumatic Metal Hub Ribbed Tread 6" x 1-1/2" (150 x 38mm) - 1/2" (13mm) bore	09590 4	1	12	Wheel Tag	1.32	6.00	1.50	-	16.48	5.91	9.09	11.81	0.37	16	
9591	REPLACEMENT WHEEL: Semi-Pneumatic Metal Hub Diamond Tread 6" x 1-1/2" (150 x 38mm) - 1/2" (13mm) bore	09591 1	1	12	Wheel Tag	1.20	6.00	1.50	-	14.79	6.30	9.45	12.20	0.42	16	
9592	REPLACEMENT WHEEL: Semi-Pneumatic Metal Hub Diamond Tread 7" x 1-1/2" (175 x 38mm) - 1/2" (13mm) bore	09592 8	1	12	Wheel Tag	1.54	7.00	1.50	-	19.84	7.09	9.06	14.17	0.53	16	
9593	REPLACEMENT WHEEL: Semi-Pneumatic Metal Hub Diamond Tread 7" x 1-1/2" (175 x 38mm) - 1/2" (13mm) bore Offset	09593 5	1	12	Wheel Tag	1.56	7.00	1.50	-	19.36	7.48	9.45	14.56	0.60	16	
9594	REPLACEMENT WHEEL: Semi-Pneumatic Metal Hub Diamond Tread 8" x 1-3/4" (200 x 44mm) - 1/2" (13mm) bore	09594 2	1	12	Wheel Tag	2.16	8.00	1.75	-	27.62	8.86	12.24	16.93	1.09	16	
9595	REPLACEMENT WHEEL: Semi-Pneumatic Metal Hub Gear Tread 8" x 1-3/4" (200 x 44mm) - 1/2" (13mm) bore	09595 9	1	12	Wheel Tag	2.31	8.00	1.75	-	30.86	8.86	12.24	16.93	0.96	16	
9596	REPLACEMENT WHEEL: Semi-Pneumatic Metal Hub Ribbed Tread 10" x 1-3/4" (250 x 44mm) - 1/2" (13mm) bore	09596 6	1	6	Wheel Tag	3.30	10.00	1.75	-	20.40	9.84	9.84	10.63	0.60	16	
9597	REPLACEMENT WHEEL: Semi-Pneumatic Metal Hub Ribbed Tread 10" x 2-3/4" (250 x 70mm) - 5/8" (16mm) bore	09597 3	1	6	Wheel Tag	5.29	10.00	2.75	-	33.07	10.75	10.75	16.73	1.02	16	
9598	REPLACEMENT WHEEL: Semi-Pneumatic Metal Hub Ribbed Tread 8" x 2-1/2" (200 x 64mm) - 5/8" (16mm) bore	09598 0	1	6	Wheel Tag	4.41	8.00	2.50	-	28.66	8.66	8.66	14.96	0.79	16	
9599	REPLACEMENT WHEEL: Semi-Pneumatic Metal Hub Diamond Tread 8" x 1-3/4" (200 x 44mm) - 1/2" (13mm) bore Offset	09599 7	1	12	Wheel Tag	2.16	8.00	1.75	-	29.32	8.86	11.61	16.93	1.09	16	
9600	REPLACEMENT WHEEL: 8" x 2-1/2" - 5/8" Bore Polypropylene hub. Ball bearings	09600 0	1	4	Wheel Tag	7.08	8.00	2.50	-	29.05	5.00	8.50	16.50	0.41	17	
9601	APPLIANCE ROLLERS: Stamped Steel	09601 7	2	10	Clamshell	2.42	1.50	6.75	17.00	24.22	7.00	17.00	17.75	1.22	5	
9602	REPLACEMENT WHEEL: 10" x 2-1/2" - 5/8" Bore Polypropylene hub. Ball bearings	09602 4	1	4	Wheel Tag	6.65	10.00	2.50	-	28.95	6.00	10.50	20.50	0.75	17	
9603	APPLIANCE ROLLERS: Aluminum	09603 1	2	5	Printed Box	2.17	1.50	3.50	21.63	21.66	7.75	8.25	22.50	0.83	5	
9606	WHEELBARROW WHEEL: 16" (400mm) Roller Bearings - 5/8" (16mm) bore	09606 2	1	1	Wheel Tag	6.17	16.00	3.31	-	7.50	16.00	6.75	16.00	1.00	17	
9610	REPLACEMENT WHEEL: Semi-Pneumatic Plastic Hub Diamond Tread 6" x 1-1/2" (150 x 38mm) - 1/2" (13mm) bore	09610 9	12	12	Wheel Tag	1.83	6.00	1.50	-	12.13	5.71	8.50	11.42	0.32	16	
9611	REPLACEMENT WHEEL: Semi-Pneumatic Plastic Hub Diamond Tread 7" x 1-1/2" (175 x 38mm) - 1/2" (13mm) bore	09611 6	12	12	Wheel Tag	1.18	7.00	1.50	-	14.70	7.48	9.45	14.96	0.61	16	

INDEX

Item Number	Description	UPC (039003)	Pcs. per Pk.	Pks./Ctn.	Package Type	Pkg. Wt (lb.)	Pkg. Height	Pkg. Width	Pkg. Depth	Carton Weight	Carton Height	Carton Width	Carton Depth	Carton	Cube (feet)	Catalog Page
9612	INNER TUBE: 480/400-8 Straight valve Stem for 8" Rim	096112 3	1	6	Clam Insert	1.00				6.50	8.66	7.09	13.70	0.49	17	
9613	REPLACEMENT WHEEL: Semi-Pneumatic Plastic Hub Diamond Tread 8" x 1-3/4" (200 x 44mm) - 1/2" (13mm) bore	096113 0	1	12	Wheel Tag	1.76	8.00	1.50	-	21.77	7.87	10.24	15.94	0.74	16	
9614	REPLACEMENT WHEEL: Semi-Pneumatic Plastic Hub Gear Tread 8" x 1-3/4" (200 x 44mm) - 1/2" (13mm) bore	096114 7	1	12	Wheel Tag	1.50	8.00	1.50	-	18.60	7.87	10.00	15.75	0.72	16	
9615	REPLACEMENT WHEEL: Semi-Pneumatic Plastic Hub Diamond Tread 10" x 1-3/4" (250 x 44mm) - 1/2" (13mm) bore	096115 4	1	6	Wheel Tag	2.43	10.00	1.50	-	16.09	9.84	9.84	9.92	0.56	16	
9629	CASTER: Soft Rubber 4" (100mm) Swivel Plate / 400 series	09629 1	1	10	Bulk	2.60	5.00	2.50	5.50	26.00	7.50	8.00	12.00	0.42	9	
9630	CASTER: Soft Rubber 4" (100mm) Swivel w/Brake / 400 series	09630 7	1	10	Bulk	3.00	5.00	3.25	5.50	30.00	5.00	3.00	8.50	0.07	9	
9634	REPLACEMENT WHEEL: 10" 4 PLY Wheel Sawtooth Tread	09634 5	1	4	Hub Insert	3.72	-	-	-	-	12.50	21.25	10.50	1.61	17	
9636	REPLACEMENT WHEEL: Semi-Pneumatic Metal Hub Centered Ribbed Tread 8" x 1-3/4" (200 x 44mm) - 1/2" (13mm) bore	09636 9	1	12	Wheel Tag	8.00	1.75	-	27.56	8.50	12.25	16.00	0.96	1.09	16	
9637	REPLACEMENT WHEEL: Semi-Pneumatic Metal Hub Centered Ribbed Tread 8" x 1-3/4" (200 x 44mm) - 5/8" (13mm) bore	09637 6	1	12	Wheel Tag	8.00	1.75	-	27.56	8.50	12.25	16.00	0.96	1.09	16	
9644	SURFACE GRIP: Anti-Skid Disc 1" (25mm)	09644 4	4	6	Blister	0.09	5.56	4.63	0.38	0.54	5.75	2.75	5.00	0.05	23	
9645	SURFACE GRIP: Anti-Skid Disc 1-1/2" (38mm)	09645 1	4	6	Blister	0.16	5.56	4.63	0.38	0.89	5.75	2.75	5.25	0.05	23	
9646	SURFACE GRIP: Anti-Skid Disc 2" (50mm)	09646 8	4	6	Blister	0.22	5.56	4.63	0.75	1.37	5.75	5.00	5.00	0.08	23	
9647	SURFACE GRIP: Anti-Skid Disc 2-1/2" (64mm)	09647 5	4	6	Blister	0.32	7.63	3.75	0.75	2.11	7.85	3.90	5.00	0.09	23	
9653	12" x 2-5/8" (300 x 66mm) Ribbed Tread - 3/4" (19mm) bore	09653 6	1	4	Wheel Tag					8.50					17	
9654	12" x 2-5/8" (300 x 66mm) Ribbed Tread - 5/8" (16mm) bore	09654 3	1	4	Wheel Tag					8.50					17	
9659	CASTER: Soft Rubber Rigid 4" (100mm) / 400 series	09659 8	1	10	Blister	2.30	-	-	-	23.00	8.00	8.00	13.00	0.48	9	
9672	CASTER: Twin Wheel 2" (50mm) Stem 07 - Black / Office Chair	09672 7	1	6	Blister	0.29	6.56	4.63	2.00	1.76	6.50	4.25	13.25	0.21	4	
9673	CASTER: Twin Wheel 2" (50mm) Stem 87 - Black / Office Chair	09673 4	1	6	Blister	0.33	6.56	4.63	2.00	1.98	6.50	4.25	13.25	0.21	4	
9674	CASTER: Twin Wheel 2" (50mm) Stem 82 - Black / Office Chair	09674 1	1	6	Blister	0.34	6.56	4.63	2.00	2.06	6.50	4.25	13.25	0.21	4	
9679	CASTER: Twin Wheel 2" (50mm) Stem 82 - Chrome / Office Chair	09679 6	1	6	Blister	0.35	6.56	4.63	2.00	2.12	6.50	4.25	13.25	0.21	4	
9685	CASTER: Hooded Ball 2" (50mm) Stem 87 - Chrome / Office Chair	09685 7	1	6	Blister	0.60	6.56	4.63	2.25	3.58	6.50	4.25	13.25	0.21	3	
9686	CASTER: Hooded Ball 2" (50mm) Stem 82 - Chrome / Office Chair	09686 4	1	6	Blister	0.37	6.56	4.63	2.50	2.24	6.75	4.25	15.25	0.25	3	
9688	CASTER: Polyolefin 2-1/2" (64mm) Friction Grip Ring Stem 82 Medium-Duty	09688 8	1	6	Blister	0.49	6.56	4.63	1.75	2.96	6.75	4.25	9.25	0.15	7	
9694	CASTER: Twin Wheel 2" (50mm) Stem 88 - Black / Office Chair	09694 9	1	6	Blister	0.34	6.56	4.63	2.00	2.06	6.50	4.25	13.25	0.21	4	
9702	REPLACEMENT WHEEL: 7" x 1-1/2" (175 x 38mm) Ribbed Tread - 1/2" (13mm) bore	09702 1	1	12	Wheel Tag	1.56	7.00	1.50	7.00	19.2	6.81	13.78	11.34	0.62	16	
9703	REPLACEMENT WHEEL: 6" x 1-1/2" (150 x 38mm) Diamond Tread - 1/2" (13mm) bore	09703 8	1	12	Wheel Tag	1.20	6.00	1.50	6.00	14.7	6.02	12.00	8.50	0.36	16	
9704	REPLACEMENT WHEEL: FLAT-FREE 10" x 3" (250 x 75mm) Sawtooth Tread - 5/8" bore	09704 7	1	4	Hub card	4.35	10.00	10.00	2.63	18.25	10.50	10.50	13.00	0.83	17	
9708	REPLACEMENT WHEEL: FLAT-FREE 15.1 x 3.74" (385 x 95mm) - 5/8" (16mm) bore	09708 3	1	4	Hub card	8.60	15.00	15.00	3.75	31.60	16.50	20.90	16.50	3.21	17	
9709	REPLACEMENT WHEEL: FLAT-FREE 4.33" x 3.10" (364 x 78mm) Universal fit w/spacers & bushings	09809 0	1	4	Hub card	7.25	14.00	14.00	3.00	29.00	15.00	14.60	13.80	1.69	17	
9733	CASTER: Twin Wheel Bulk 2" (50mm) Threaded Stem 07 - Black / Office Chair	09733 5	1	24	Blister	0.34	6.56	4.63	2.00	2.06	6.50	4.25	13.25	0.21	4	
9735	CASTER: Soft TPR Swivel 4" (100mm) - Plate / 400 series	09735 9	1	4	Bulk	1.13	-	-	-	4.54	5.38	8.00	9.00	0.22	N/A	
9736	CASTER: Soft TPR Swivel 4" (100mm) - Plate w/Brake / 400 series	09736 6	1	4	Bulk	1.50	-	-	-	6.00	5.38	10.00	9.00	0.28	N/A	
9737	CASTER: Soft TPR Rigid 4" (100mm) / 400 series	09737 3	1	4	Bulk	1.13	-	-	-	4.54	5.38	6.25	9.00	0.17	N/A	
9738	CASTER: Soft TPR Swivel 5" (125mm) - Plate / 400 series	09738 0	1	4	Bulk	2.87	-	-	-	11.5	6.38	8.00	9.00	0.27	N/A	
9740	CASTER: Soft TPR Rigid 5" (125mm) / 400 series	09740 3	1	4	Bulk	2.29	-	-	-	9.17	6.38	8.00	9.00	0.27	N/A	
9741	CASTER: Twin Wheel Bulk 2" (50mm) Stem 88 - Black / Office Chair	09741 0	1	24	Blister	0.34	6.56	4.63	2.00	2.06	6.50	4.25	13.25	0.21	4	
9742	CRUTCH TIP: Rubber Off-White 3/4" - 7/8" (19 - 22mm)	09742 7	2	6	Blister	0.38	5.56	4.63	1.88	2.26	6.00	4.75	11.25	0.19	32	
9743	LEG TIP: Rubber Bulk Off-White 1-1/4" (32mm) - Round	09743 4	1	24	Bulk	0.10	2.00	1.25	1.25	2.35	15.00	10.5	15.5	1.41	33	

Item Number	Description	UPC (039003)	Pcs. per Pk.	Pks./ Ctn.	Package Type	Pkg Wt. (lb.)	Pkg Height	Pkg Width	Pkg Depth	Carton Weight	Carton Height	Carton Width	Carton Depth	Carton	Cube (feet)	Catalog Page
9744	LEG TIP: Plastic Bulk White 1-1/8" (29mm) - Round	09744 1	4	6	Blister	0.09	5.56	4.63	0.88	0.56	7.00	4.75	7.50	7.50	0.14	32
9745	LEG TIP: Plastic Bulk White 1-1/4" (32mm) - Round	09745 8	4	6	Blister	0.09	5.56	4.63	0.88	0.56	7.00	4.75	7.50	7.50	0.14	32
9746	LEG TIP: Rubber Bulk Black 1-1/4" (32mm) - Round	09746 5	1	24	Bulk	0.10	2.00	1.25	1.25	2.30	15.00	10.50	15.50	15.50	1.41	33
9751	LEG TIP: Rubber Bulk Off-White 1/2" (13mm) - Round	09751 9	1	24	Bulk	0.02	1.00	0.50	0.50	0.58	11.00	7.38	9.50	9.50	0.45	33
9752	LEG TIP: Rubber Bulk Off-White 5/8" (16mm) - Round	09752 6	1	24	Bulk	0.03	1.13	1.13	1.13	0.65	11.00	7.38	9.50	9.50	0.45	33
9753	LEG TIP: Rubber Bulk Off-White 3/4" (19mm) - Round	09753 3	1	24	Bulk	0.04	1.13	1.25	1.25	1.01	11.25	8.75	12.25	12.25	0.70	33
9754	LEG TIP: Rubber Bulk Off-White 7/8" (22mm) - Round	09754 0	1	24	Bulk	0.04	1.25	1.25	1.25	1.03	11.25	8.75	12.25	12.25	0.70	33
9755	LEG TIP: Rubber Bulk Off-White 1" (25mm) - Round	09755 7	1	24	Bulk	0.07	1.50	1.50	1.50	1.63	15.00	10.50	15.50	15.50	1.41	33
9756	LEG TIP: Rubber Bulk Off-White 1-1/8" (29mm) - Round	09756 4	1	24	Bulk	0.07	1.50	1.63	1.63	1.75	15.00	10.50	15.50	15.50	1.41	33
9758	LEG TIP: Rubber Bulk Black 1/2" (13mm) - Round	09758 8	1	24	Bulk	0.02	1.00	0.88	0.38	0.55	11.00	7.38	9.50	9.50	0.45	33
9759	LEG TIP: Rubber Bulk Black 5/8" (16mm) - Round	09759 5	1	24	Bulk	0.03	1.13	1.13	1.13	0.67	11.00	7.38	9.50	9.50	0.45	33
9760	LEG TIP: Rubber Bulk Black 3/4" (19mm) - Round	09760 1	1	24	Bulk	0.04	1.13	1.25	1.25	0.96	11.25	8.75	12.25	12.25	0.70	33
9761	LEG TIP: Rubber Bulk Black 7/8" (22mm) - Round	09761 8	1	24	Bulk	0.04	1.25	1.25	1.25	1.03	11.25	8.75	12.25	12.25	0.70	33
9762	LEG TIP: Rubber Bulk Black 1" (25mm) - Round	09762 5	1	24	Bulk	0.07	1.50	1.50	1.50	1.66	15.00	10.50	15.50	15.50	1.41	33
9763	LEG TIP: Rubber Bulk Black 1-1/8" (29mm) - Round	09763 2	1	24	Bulk	0.07	1.50	1.63	1.63	1.63	15.00	10.50	15.50	15.50	1.41	33
9765	LEG TIP: Rubber Bulk Off-White 1-1/2" (38mm) - Round	09765 6	1	12	Blister	0.13	1.88	2.00	2.00	1.50	10.75	15.50	15.00	15.00	1.45	33
9766	LEG TIP: Rubber Bulk Black 1-1/2" (38mm) - Round	09766 3	1	12	Blister	0.13	1.88	2.00	2.00	1.50	10.75	15.50	15.00	15.00	1.45	33
9768	LEG TIP: Plastic Black 1-1/8" (29mm) - Round	09768 7	4	6	Blister	0.11	5.56	4.63	0.88	0.66	7.00	4.75	7.50	7.50	0.14	32
9769	LEG TIP: Plastic Black 1-1/4" (32mm) - Round	09769 4	4	6	Blister	0.12	5.56	4.63	0.88	0.70	7.00	4.75	7.50	7.50	0.14	32
9770	CASTER: Phenolic Swivel 4" (100mm) Plate / 1400 series	09770 0	1	4	Blister	4.70	5.50	4.00	4.00	5.50	18.78	12.00	10.00	10.00	0.43	14
9771	CASTER: Phenolic Rigid 4" (100mm) / 1400 series	09771 7	1	4	Blister	3.96	5.50	4.00	4.50	15.82	6.75	12.00	10.00	10.00	0.47	14
9774	CASTER: Phenolic Swivel 6" (150mm) Plate / 1400 series	09774 8	1	4	Blister	6.15	7.50	4.00	6.75	24.60	9.75	12.00	10.00	10.00	0.68	14
9775	CASTER: Phenolic Rigid 6" (150mm) / 1400 series	09775 5	1	4	Blister	5.44	7.25	4.00	6.00	21.74	9.75	12.00	10.00	10.00	0.68	14
9778	CASTER: Phenolic Swivel 6" (150mm) Plate w/Brake / 1400 series	09778 6	1	4	Blister	8.02	9.50	4.00	8.25	26.10	8.03	9.00	13.50	13.50	0.57	14
9779	CASTER: Phenolic Swivel 4" (100mm) Plate w/Brake / 1400 series	09779 3	1	4	Blister	—	7.50	4.00	8.25	26.10	8.03	9.00	13.50	13.50	0.57	14
9780	CASTER: Cast-Iron Swivel 3" (75mm) Plate	09780 9	1	4	Blister	2.75	3.75	3.13	4.50	11.00	6.25	12.00	10.00	10.00	0.43	12
9781	CASTER: Cast-Iron Rigid 3" (75mm)	09781 6	1	4	Blister	2.13	3.88	2.38	4.88	8.50	6.25	12.00	10.00	10.00	0.43	12
9782	CASTER: Cast-Iron 4" (100mm) Swivel Plate	09782 3	1	4	Blister	3.79	5.00	4.00	6.00	15.14	6.25	12.00	10.00	10.00	0.43	12
9783	CASTER: Cast-Iron 4" (100mm) Rigid	09783 0	1	4	Blister	3.31	5.00	3.00	6.13	13.24	6.25	12.00	10.00	10.00	0.43	12
9784	CASTER: Polypropylene 4" (100mm) Swivel Plate / 400 Series	09784 7	1	4	Bulk	1.45	—	—	—	5.80	5.25	8.25	9.75	9.75	0.24	13
9785	CASTER: GATE: Hard Rubber 4" (100mm) Wheel - Spring Loaded	09785 4	1	6	Wrap Label	2.05	10.75	1.88	4.13	20.10	7.75	8.75	11.75	11.75	0.46	15
9786	CASTER: Polypropylene 4" (100mm) Rigid / 400 Series	09786 1	1	4	Bulk	1.13	—	—	—	4.54	5.38	8.25	9.00	9.00	0.46	13
9787	CASTER: Soft Rubber 5" (125mm) Swivel Plate	09787 8	1	4	Bulk	2.83	6.13	2.38	5.50	11.32	6.25	12.00	10.00	10.00	0.43	8
9788	CASTER: Soft Rubber 5" (125mm) Swivel Plate w/Brake	09788 5	1	4	Bulk	3.03	6.13	3.25	5.50	12.12	6.25	12.00	10.00	10.00	0.43	8
9789	CASTER: Soft Rubber 5" (125mm) Rigid	09789 2	1	4	Bulk	2.18	6.00	2.38	5.00	8.72	6.25	12.00	10.00	10.00	0.43	8
9790	CASTER: TPR Bulk 2"x13/16" - Stem 82	09790 8	1	24	Bulk	0.33	—	—	—	7.90	4.75	8.25	8.50	8.50	0.19	10
9792	REPLACEMENT WHEEL: 8" (200mm) Pneumatic 19-8 X 2.5 4 ply centered bore	09792 2	1	4	Hub Label	2.48	8.00	2.50	8.00	11.68	15.55	9.45	9.45	9.45	0.80	17
9793	REPLACEMENT WHEEL: 10" (250mm) Pneumatic 19-10 X 3.5 4 ply centered 5/8" (16mm) bore	09793 9	1	4	Hub Label	10.00	3.06	—	17.20	10.83	10.83	15.94	1.03	1.03	1.03	17
9794	CASTER: Pneumatic Swivel 8" (200mm) Plate	09794 6	1	4	Bulk	7.28	9.88	4.75	8.00	29.10	8.50	11.00	18.00	18.00	0.97	15
9795	CASTER: Pneumatic Rigid 8" (200mm)	09795 3	1	4	Bulk	6.38	9.88	5.00	8.00	25.52	8.50	11.00	18.00	18.00	0.97	15
9796	CASTER: Pneumatic Swivel 10" (250mm) Plate	09796 0	1	4	Bulk	—	—	—	—	34.17	12.50	11.00	20.88	20.88	0.97	15

INDEX

Item Number	Description	UPC (039003)	Pcs. per Pk.	Pks./Ctn.	Package Type	Pkg. Wt (lb.)	Pkg. Height	Pkg. Width	Pkg. Depth	Carton Weight	Carton Height	Carton Width	Carton Depth	Carton	Cube (feet)	Catalog Page
9797	CASTER: Pneumatic Rigid 10" (250mm)	09797 7	1	4	Bulk	-	-	-	-	30.86	12.63	10.75	21.38	0.97	15	
9798	CASTER: Gate Spring Loaded Pneumatic Wheel 8" (200mm)	09798 4	1	4	Bulk	8.05	5.00	9.00	18.00	32.70	10.00	20.00	14.00	1.62	15	
9807	CASTER: TPR Soft Grey Non-Marking Swivel 3" (75mm) - Stem	09807 3	1	12	Blister	-	-	-	-	11.90	5.00	6.13	15.25	0.27	10	
9815	FELT GARD: H-D Felt 1" (25mm) Square Pad	09815 8	16	12	Blister	0.10	5.56	4.63	0.75	0.61	5.88	5.00	4.88	0.08	22	
9816	FELT GARD: H-D Felt 1-1/2" x 1-1/2" (38 x 38mm) Corner Pad	09816 5	8	12	Blister	0.08	5.56	4.63	1.00	0.46	5.88	5.13	3.13	0.05	22	
9817	FELT GARD: H-D Felt 2 x 2" x 2-1/2" (50 x 50 x 64mm) Triangle Pad	09817 2	4	12	Blister	0.05	5.56	4.63	0.75	0.32	5.75	5.00	2.00	0.03	22	
9818	FELT GARD: H-D Felt 1/2" x 58" (13 mm x 1.5m) Roll	09818 9	1	12	Blister	0.10	5.56	4.63	0.75	0.63	5.75	5.25	4.25	0.07	22	
9819	FELT GARD: 1" (25mm) Round Pad w/ Nylon Insert	09819 6	8	12	Blister	0.06	5.56	4.63	0.75	0.72	6.00	4.75	10.00	0.16	22	
9820	SURFACE GARD: Felt Medium-Duty 1/2" (13mm) Round Green Pads	09820 2	24	12	Blister	0.02	4.56	3.63	0.25	0.19	4.88	4.00	2.63	0.03	28	
9821	SURFACE GARD: Felt Medium-Duty 3/4" (19mm) Round Green Pads	09821 9	12	12	Blister	0.02	4.56	3.63	0.50	0.21	5.00	4.00	3.25	0.04	28	
9822	SURFACE GARD: Felt Medium-Duty 1" (25mm) Round Brown Pads	09822 6	4	12	Blister	0.02	4.56	3.63	0.25	0.17	5.00	4.13	1.75	0.02	28	
9823	SURFACE GARD: Felt Medium-Duty 1" (25mm) Square Brown Pads	09823 3	4	12	Blister	0.02	4.56	3.63	0.13	0.16	5.00	4.13	1.75	0.02	28	
9824	FELT GARD PLUS: Value pack of 9825 & 9826 Round Cups/4 pcs 1-1/2" (38mm) 16 pcs of 1" (25mm)	09824 0	20	6	Blister	0.35	8.75	5.62	0.75	2.43	9.06	5.90	5.90	0.18	20	
9825	FELT GARD PLUS: Cup 1" (25mm) Round	09825 7	4	6	Blister	0.06	5.56	4.63	0.38	0.43	5.88	5.00	3.50	0.06	20	
9826	FELT GARD PLUS: Cup 1-1/2" (38mm) Round	09826 4	4	6	Blister	0.11	5.56	4.63	0.75	0.77	5.38	5.00	5.38	0.08	20	
9827	FELT GARD PLUS: Cup 2" (50mm) Round	09827 1	4	6	Blister	0.19	7.75	4.63	0.75	1.32	8.00	5.00	5.63	0.13	20	
9828	FELT GARD PLUS: Cup 2-1/2" (64mm) Round	09828 8	4	6	Blister	0.31	7.75	4.63	1.00	1.88	8.00	5.00	6.63	0.15	20	
9829	FELT GARD PLUS: Cup 1-1/2" (38mm) Square	09829 5	4	6	Blister	0.13	5.56	4.63	0.75	0.90	6.00	5.00	5.50	0.09	20	
9830	FELT GARD PLUS: Cup 2-1/2" (64mm) Square	09830 1	4	6	Blister	0.36	7.75	4.63	1.00	2.31	8.00	5.00	6.75	0.16	20	
9831	FELT GARD PLUS: Cup 1-1/2" x 4" (38 x 100mm) Rectangle	09831 8	4	6	Blister	0.34	5.56	4.63	0.75	2.22	8.00	5.00	6.50	0.15	20	
9838	FELT GARD: Value Pack Assortment 194 pcs	09838 7	194	10	Clamshell	0.90	-	-	-	-	-	-	-	-	43	
9839	FELT GARD: Value Pack Assortment 118 pcs	09839 4	118	12	Clamshell	0.84	11.61	15.55	1.54	9.48	12.40	16.34	11.42	1.34	43	
9840	FELT GARD: 8 pcs of 3/4" felt w/ nylon discs (very similar to 9819) + a drill bit and a screw/nail that can be hammered or screwed-in.	09840 0	8	6	Blister	0.06	5.56	4.63	0.91	0.53	5.79	6.14	4.96	0.10	23	
9841	FELT GARD: 8 pcs of 1" felt w/ nylon discs (very similar to 9819) + a drill bit and a screw/nail that can be hammered or screwed-in.	09841 7	8	6	Blister	0.08	5.56	4.63	1.08	0.69	5.79	6.88	4.96	0.11	23	
9842	FELT GARD: 1-1/2" felt w/ nylon discs (very similar to 9819) + a drill bit and a screw/nail that can be hammered or screwed-in.	09842 4	4	6	Blister	0.07	5.56	4.63	1.48	0.79	5.71	8.66	4.92	0.14	23	
9843	FELT GARD: - Value Pack of 16 pcs of 1" felt w/ nylon discs (9841) and 4 pcs of 1-1/2" of felt w/ nylon discs (9842) + drill bit and a screw/nail that can be hammered or screwed-in.	09843 1	20	4	Blister	0.20	8.75	5.62	1.48	1.08	9.06	5.90	5.90	0.18	23	
9844	FELT GARD: Self-adhesive Felt Pad 1" x 3-3/4" (25 x 95mm)	09844 8	4	6	Blister	0.10	5.50	4.63	0.75	0.87	5.78	6.14	5.00	0.10	23	
9845	FELT GARD: 1" x 3-3/4" (25 x 95mm) Felt Pad with Nylon Insert.	09845 5	4	6	Blister	0.13	5.56	4.63	1.10	1.15	5.79	6.89	4.96	0.12	22	
9846	PLATFORM CART: Large 24" x 36" (60 x 90cm)	09846 2	1	1	Blister	43.70	33.00	24.00	36.00	43.70	5.00	24.5	36.00	2.55	18	
9847	PLATFORM CART: Small 19" x 29" (48 x 74cm)	09847 9	1	1	Blister	26.50	33.00	19.00	29.00	26.50	3.25	18.75	29.50	1.04	18	
9848	APPLIANCE ROLLERS: Plastic 19" x 28" (48.3 x 63.5cm)	09848 6	2	10	Blister	1.52	3.00	6.25	25.25	15.24	14.50	6.50	19.25	1.05	5	
9850	MOVERS DOLLY: 20" x 31" (50 x 77cm)	09850 9	1	4	Blister	11.50	-	-	-	53.00	30.50	13.78	20.86	5.10	18	
9851	MOVERS BLANKET: 72" X 80" (183 X 203cm)	09851 6	1	6	Blister	6.33	66.00	76.00	-	38.00	18.00	18.50	24.00	4.63	36	
9853	FLEECE: Blanket 3' x 5' (1M x 1.5M)	09853 0	1	10	Polybag	0.60	1.15	15.00	15.00	7.50	12.00	15.00	15.00	0.15	36	
9854	MOVERS DOLLY: 12.5" x 18.25" (32 x 46cm) Solid Wood Top	09854 7	1	5	Blister	7.70	5.00	12.25	18.25	38.50	14.50	20.75	15.50	2.70	18	
9855	3-in-1 VALUE PACK Assortment - 4" (75mm) H-D Felt Pads / Anti-Skid Pads / SlideGlide Cups	09855 4	12	4	Blister	0.22	15.69	6.00	1.63	3.10	16.00	6.50	6.50	0.38	20,42	
9858	CASTER: Polypropylene 4" (100mm) Swivel Plate w/Braze / 400 Series	09858 5	1	4	Blister	3.75	-	-	-	15.00	9.00	8.00	14.75	0.61	N/A	
9859	FLEECE: Roll 3' x 16' (1M x 5M)	09859 2	1	5	Polybag	2.00	3.00	3.00	40.00	11.80	3.00	40.00	15.00	0.21	36	
9859D	DISPLAY MERCHANDISER: POP Fleece Display contains 20 fleece rolls	09859 2	1	20	Carton	45.00	-	-	-	-	-	-	-	-	36	
9870	FELT GARD Sheet: Super Stick w/Hook & Loop 4-1/4" x 6" (108 x 150mm) Rectangle	09870 7	1	6	Blister	0.13	8.75	5.62	0.47	0.91	10.20	3.55	5.95	0.13	22	

Item Number	Description	UPC (039003)	Pcs. per Pk.	Pks./ Ctn.	Package Type	Pkg Wt. (lb.)	Pkg Height	Pkg Width	Pkg Depth	Carton Weight	Carton Height	Carton Width	Carton Depth	Carton	Cube (feet)	Catalog Page
9892	FELT GARD Pad: Super Stick w/Hook & Loop 1-1/2" (38mm) Round	09892 9	4	6	Blister	0.04	7.25	4.63	0.36	0.31	7.95	2.68	5.12	0.07	0.07	22
9901	MERCHANDISING TRAY: Contains 52 cards of 9951	09901 8	20	52	Blister	0.73	5.56	4.63	0.75	-	-	-	-	-	-	40
9902	MERCHANDISING TRAY: Contains 52 cards of 9952	09902 5	16	52	Blister	0.83	5.56	4.63	0.75	-	-	-	-	-	-	40
9903	MERCHANDISING TRAY: Contains 52 cards of 9953	09903 2	8	52	Blister	0.86	5.56	4.63	0.75	-	-	-	-	-	-	40
9908	FELT GARD PLUS: Felt Glide 1" (25mm) Almond Threaded Stem 1/4" - 20 x 1" (7mm - 20 x 25mm)	09908 7	4	6	Blister	0.11	4.56	3.63	1.00	0.68	5.00	4.00	6.50	0.08	0.08	20
9909	FELT GARD PLUS: Felt Glide 1-1/2" (38mm) Almond Threaded Stem 1/4" - 20 x 1" (7mm - 20 x 25mm)	09909 4	4	6	Blister	0.16	4.56	3.63	1.38	0.94	5.00	4.00	9.00	0.10	0.10	20
9910	FELT GARD PLUS: Felt Glide w/Nail 7/8" (22mm) Almond	09910 0	8	12	Blister	0.08	5.50	4.63	1.00	1.20	6.00	5.00	12.5	0.22	0.22	20
9911	FELT GARD PLUS: Felt Glide w/Nail 1-1/2" (38mm) Almond	09911 7	4	12	Blister	0.09	5.50	4.63	0.88	1.40	6.00	5.00	12.5	0.22	0.22	20
9912Pb	FELT GARD: BIG VALUE PACK Heavy duty Felt 26 pcs Polybag	09912 4	26	20	Polybag	0.17	-	-	-	-	-	-	-	-	0.55	22
9913	FELT GARD: Dinette Pack Felt Set 16 pcs 1" (25mm) pads & 4 pcs 1-1/2" (38mm) Pads	09913 1	20	12	Blister	0.09	5.56	4.63	0.50	0.95	5.70	4.92	6.30	0.10	0.10	22
9914	FELT GARD: Leveling Felt Combo Pack 1" (25mm) & 1-1/2" (38mm) Pads	09914 8	24	6	Blister	0.13	9.63	4.88	0.50	0.97	5.00	5.90	9.80	0.17	0.17	20
9915	FELT GARD: Leveling Felt 1" (25mm) Pads	09915 5	8	6	Blister	0.06	5.50	4.63	0.50	0.34	5.88	5.00	2.75	0.05	0.05	20
9916	FELT GARD: Leveling Felt 1-1/2" (38mm) Pads	09916 2	4	6	Blister	0.06	5.50	4.63	0.50	0.35	5.88	5.00	2.75	0.05	0.05	20
9917	Combo Pack Assortment of FeltGard & Slide Glide Pads 58 pcs	09917 9	58	6	Clamshell	1.00	-	-	-	-	-	-	-	-	-	42
9918	FELT GARD PLUS: 1" (25mm) w/Nail - Almond	09918 6	8	12	Blister	0.10	-	-	-	-	-	-	-	-	-	20
9923	POWER PANEL: FELT GARD Loaded with 18 pcs of 9951 & 9953 and 72 pcs of 9952	-	108	1	Blister	18.70	8.00	16.5	49.00	18.70	8.00	16.5	49	3.74	4.0	40
9927	FELT GARD: Heavy-Duty Felt 2" (50mm) Pads Self-Adhesive	09927 8	4	6	Blister	0.05	5.56	4.63	0.33	0.39	5.88	5.00	2.88	0.05	0.05	22
9928	FELT GARD: Heavy-Duty Felt 3" (75mm) Pads Self-Adhesive	09928 5	4	6	Blister	0.09	5.56	4.63	1.00	0.69	5.88	5.00	6.19	0.11	0.11	22
9930	FELT GARD Pad: Super Stick w/Hook & Loop 1" (25mm) Round	09930 8	16	6	Blister	0.04	7.25	4.63	0.36	0.28	7.95	2.68	5.12	0.07	0.07	22
9931	FELT GARD Pad: Super Stick w/Hook & Loop 3/4" (19mm) Round	09931 5	20	6	Blister	0.03	7.25	4.63	0.36	0.24	7.95	2.68	5.12	0.07	0.07	22
9933	FELT GARD PLUS: Felt Glide w/Hollow Nail 7/8" (22mm) Almond	09933 9	8	6	Blister	0.09	5.56	4.63	0.63	0.50	6.00	5.00	4.5	0.08	0.08	20
9934	FELT GARD PLUS: Felt Glide w/Hollow Nail 1" (25mm) Almond	09934 6	8	12	Blister	0.10	5.56	4.63	0.63	1.18	6.00	4.75	9.00	0.15	0.15	20
9935	FELT GARD PLUS: Felt Glide w/Hollow Nail 1-1/2" (38mm) Almond	09935 3	4	12	Blister	0.10	5.56	4.63	0.63	1.16	6.00	4.75	9.00	0.15	0.15	20
9936	FELT GARD PLUS: Felt Glide w/Hollow Nail Dinette Set Almond	09936 0	20	12	Blister	0.25	9.88	5.63	0.75	3.00	10.00	6.00	10.00	0.35	0.35	20
9937	FELT GARD: 1/2" x 2-5/8" (13 x 67mm) Self-Adhesive Strip Pads	09937 7	16	12	Blister	0.10	5.50	4.63	-	-	-	-	-	-	24	24
9938	FELT GARD PLUS: Glide Swivel 1" (25mm) Brass Almond Felt	09938 4	4	6	Blister	0.19	4.56	3.63	1.38	1.16	6.00	4.75	9.00	0.10	0.10	20
9939	FELT GARD: H-D Felt Nail-On Dinette Value Pack	09939 1	20	12	Blister	0.25	9.88	5.63	1.00	3.20	10.25	5.75	11.5	0.392	0.392	20
9941	SURFACE GARD: Felt Medium-Duty Value Pack	09941 4	99	36	Blister	0.23	8.75	5.63	0.75	8.17	9.00	18.00	10.5	0.98	0.98	28
9943	SURFACE GARD: Value Pack Cork, Foam, Vinyl Pads	09943 8	88	36	Blister	0.23	8.75	5.63	0.50	8.17	9.00	18.00	10.5	0.98	0.98	29
9943D	SURFACE GARD: Value Pack Cork, Foam, Vinyl Pads	09943 8	88	12	Blister	0.23	9.88	5.63	0.50	2.72	9.00	18.00	3.5	0.98	0.98	29
9947	FELT GARD: Value Pack	09947 6	27	12	Blister	0.16	8.75	5.63	0.75	2.20	10.63	5.88	9.88	0.36	0.36	22
9947S	FELT GARD: Value Pack - Clip Strip	09947 9	27	12	Blister	0.22	9.88	5.63	0.75	2.67	10.20	5.75	9.60	0.33	0.33	40
9948	FELT GARD: 2" x 4" (60 x 100mm) Sheet	09948 3	3	12	Blister	0.08	5.56	4.63	-	0.98	6.00	4.75	9.00	0.15	0.15	22
9949	SURFACE GARD: Felt Medium-Duty 3/8" (10mm) Round Brown Pads	09949 0	75	12	Blister	0.05	4.56	3.63	0.38	0.62	6.00	4.75	9.00	0.15	0.15	28
9950	FELT GARD: 4-1/4" x 6" (108 x 150mm) Sheet	09950 6	2	12	Blister	0.17	8.75	5.63	0.50	2.04	10.25	5.75	6.25	0.21	0.21	22
9951	FELT GARD: Heavy-Duty Felt 3/4" (19mm) Pad Self-Adhesive	09951 3	20	12	Blister	0.06	5.56	4.63	0.75	0.72	7.00	4.75	8.50	0.16	0.16	22
9951S	FELT GARD: Heavy-Duty Felt 3/4" (19mm) Pad - Clip Strip	09951 3	20	12	Blister	0.06	5.56	4.63	0.75	0.72	7.00	4.75	8.50	0.16	0.16	40
9952	FELT GARD: Heavy-Duty Felt 1" (25mm) Pad Self-Adhesive	09952 0	16	12	Blister	0.07	5.56	4.63	0.75	0.82	7.00	4.75	8.50	0.16	0.16	22
9952S	FELT GARD: Heavy-Duty Felt 1" (25mm) Pad - Clip Strip	09952 3	16	12	Blister	0.07	5.56	4.63	0.75	0.82	7.00	4.75	8.50	0.16	0.16	40
9953	FELT GARD: Heavy-Duty Felt 1-1/2" (38mm) Pad Self-Adhesive	09953 7	8	12	Blister	0.07	5.56	4.63	0.75	0.86	7.00	4.75	8.50	0.16	0.16	22
9953S	FELT GARD: Heavy-Duty Felt 1-1/2" (38mm) Pad - Clip Strip	09953 7	8	12	Blister	0.07	5.56	4.63	0.75	0.86	7.00	4.75	8.50	0.16	0.16	40
9954	FELT GARD: Heavy-Duty Felt 1/2" x 6" (13 x 150mm) Strip Self-Adhesive	09954 4	9	12	Blister	0.12	8.75	5.63	0.50	1.44	10.25	5.75	6.25	0.21	0.21	22

INDEX

Item Number	Description	UPC (039003)	Pcs. per Pk.	Pks./ Ctn.	Package Type	Pkg. Wt. (lb.)	Pkg. Height	Pkg. Width	Pkg. Depth	Carton Weight	Carton Height	Carton Width	Carton Depth	Carton Cube (feet)	Catalog Page
9955	FELT GARD: Heavy-Duty Felt 1" (25mm) Pad w/ 1-1/8" (29mm) Glide	09955 1	8	6	Blister	0.19	5.56	4.63	1.38	1.16	6.00	4.75	9.00	0.15	22
9956	SURFACE GARD: Felt Medium-Duty 4-1/4" x 6" (108 x 150mm) Brown Sheet Self-Adhesive	09956 8	2	12	Blister	0.12	9.88	5.63	0.50	1.42	10.25	5.75	6.25	0.21	28
9957	SURFACE GARD: Felt Medium-Duty 3/8" (10mm) Round White Pads Self-Adhesive	09957 5	75	12	Blister	0.05	4.56	3.63	0.38	0.64	6.00	4.75	9.00	0.15	28
9958	SURFACE GARD: Felt Medium-Duty 1/2" (13mm) Round Brown Pads Self-Adhesive	09958 2	24	12	Blister	0.05	4.56	3.63	0.25	0.54	7.00	4.75	6.25	0.12	28
9959	SURFACE GARD: Felt Medium-Duty 3/4" (19mm) Round Brown Pads Self-Adhesive	09959 9	12	12	Blister	0.05	4.56	3.63	0.50	0.58	7.00	4.75	6.25	0.12	28
9960	SURFACE GARD: Felt Medium-Duty 3/4" (19mm) Square Brown Pads Self-Adhesive	09960 5	12	12	Blister	0.05	4.56	3.63	0.50	0.60	7.00	4.75	6.25	0.12	28
9961	SURFACE GARD: Cork 3/4" Pads (19mm) Round	09961 2	12	12	Blister	0.05	4.56	3.63	0.75	0.54	7.00	4.75	6.25	0.12	29
9962	SURFACE GARD: Cork 1/2" Pads (13mm) Round	09962 9	24	6	Blister	0.05	4.56	3.63	0.50	0.54	7.00	4.75	6.25	0.12	29
9964	SURFACE GARD: Vinyl 3/8" Pads (10mm) Round Clear	09964 3	16	12	Blister	0.06	4.56	3.63	0.50	0.72	7.00	4.75	6.25	0.12	29
9964S	SURFACE GARD: Vinyl 3/8" Pads (10mm) Round Clear - Clip Strip	09964 6	16	12	Blister	0.06	4.56	3.63	0.50	0.72	7.00	4.75	6.25	0.12	40
9965	SURFACE GARD: Vinyl 3/4" Pads (19mm) Round Clear	09965 0	8	12	Blister	0.04	4.56	3.63	0.75	0.48	7.00	4.75	6.25	0.12	29
9966	SURFACE GARD: Vinyl 3/4" Pads (19mm) Round Clear Non-Adhesive	09966 7	10	12	Blister	0.05	4.56	3.63	0.25	0.56	7.00	4.75	6.25	0.12	29
9967	SURFACE GARD: Vinyl 1/2" Pads (13mm) Round Clear	09967 4	16	12	Blister	0.02	4.56	3.63	0.50	0.74	7.00	4.75	6.25	0.12	29
9967S	SURFACE GARD: Vinyl 1/2" Pads (13mm) Round Clear - Clip Strip	09967 4	16	12	Blister	0.02	4.56	3.63	0.50	0.74	7.00	4.75	6.25	0.12	40
9968	POWER PANEL: Slide Glide®	-	84	1	Power Panel	14.00	-	-	-	-	-	-	-	3.10	40
9969	SURFACE GARD: Vinyl Pads Value Pack Assortment	09969 8	36	12	Blister	0.08	5.56	4.63	0.50	0.95	7.00	4.75	6.25	0.12	29
9970	SURFACE GRIP: Foam Anti-Skid Pads 2" (50mm) Round	09970 4	8	12	Blister	0.03	5.50	4.63	0.28	0.53	5.79	5.16	3.74	0.07	23
9971	SURFACE GRIP: Foam Anti-Skid Pads 1-1/2" (38mm) Round	09971 0	8	12	Blister	0.04	5.50	4.63	0.47	0.73	5.79	5.16	6.10	0.11	23
9972	FELT GARD: 1" (25mm) Pad Bonus Pack	09972 8	48	6	Blister	0.85	5.56	4.63	1.50	0.74	6.00	4.75	10.00	0.17	22
9973	SURFACE GARD: Foam Pads 3/4" (19mm) Round	09973 5	12	6	Blister	0.05	4.56	3.63	0.75	0.54	7.00	4.75	6.25	0.12	29
9974	SURFACE GARD: Foam Pads 1/2" (13mm) Round	09974 2	24	6	Blister	0.05	4.56	3.63	0.50	0.54	7.00	4.75	6.25	0.12	29
9976	FELT GARD: 1-1/2" (38mm) Pad Bonus Pack	09976 6	24	6	Blister	0.10	5.56	4.63	1.75	0.83	6.00	4.75	10.00	0.17	22
9980	SURFACE GARD: Foam 3/8" X 2-3/8" (10 X 60mm) Strip	09980 3	6	12	Blister	0.04	4.56	3.63	0.50	0.50	7.00	4.75	8.50	0.16	28
9982	VINYL HOOKS: Plant Hook	09982 7	2	12	Blister	0.20	8.50	3.88	0.38	2.45	8.75	5.50	4.25	0.12	37
9984	VINYL HOOKS: All Purpose Hook	09984 1	2	12	Blister	0.45	10.63	5.38	0.38	5.35	11.00	5.63	5.58	0.20	37
9985	VINYL HOOKS: Ladder Hook	09985 8	2	12	Blister	0.30	10.50	4.25	0.38	3.95	11.00	5.50	4.50	0.16	37
9986	VINYL HOOKS: Bicycle Hook	09986 5	2	12	Blister	0.30	8.50	3.88	0.38	3.50	8.75	5.38	4.25	0.12	37
9987	VINYL HOOKS: Tool Hook	09987 2	2	12	Blister	0.25	8.50	4.00	0.50	2.95	8.75	7.88	4.25	0.17	37
9988	VINYL HOOKS: Rafter Hook	09988 9	2	12	Blister	0.40	8.50	3.88	0.50	4.85	8.75	9.75	4.00	0.20	37
9989	POWER PANEL: Felt Gard	-	144	1	Power Panel	15.00	-	-	-	15.00	51.00	15.00	7.00	3.10	40

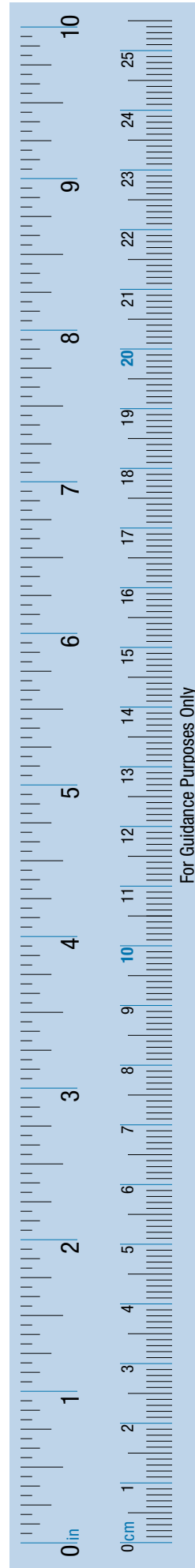

For Guidance Purposes Only

Shepherd Hardware Products LLC
Three Oaks, Michigan USA 49128-0394
PH: (269) 756-3830 or (800) 645-8990
FAX: (269) 756-3848

Shepherd Hardware Products LLC
Apodaca, N.L. Mexico CP 66600
PH: (52) 81-8-369-4700

Shepherd Hardware Products S.A.S.
Épône 78680, France
Tél +33 (0) 1 30 95 78 03 Fax +33 (0)1 30 95 78 29

Shepherd Hardware Products Ltd.
Richmond Hill, ON Canada L4B 1G5
PH: (905) 709-4488 FAX: (905) 881-7283

Select Hardware Limited
Birmingham, West Midlands, UK B65 0LJ
PH: (44) 121-561-6070 FAX: (44) 121-561-6080

EHI Australia Pty. Ltd.
Wangara, WA AUS 6065
PH: (61) 8-9406-6333 FAX: (61) 8-9406-6331

www.shepherdhardware.com



Colson Associates, Inc.

